

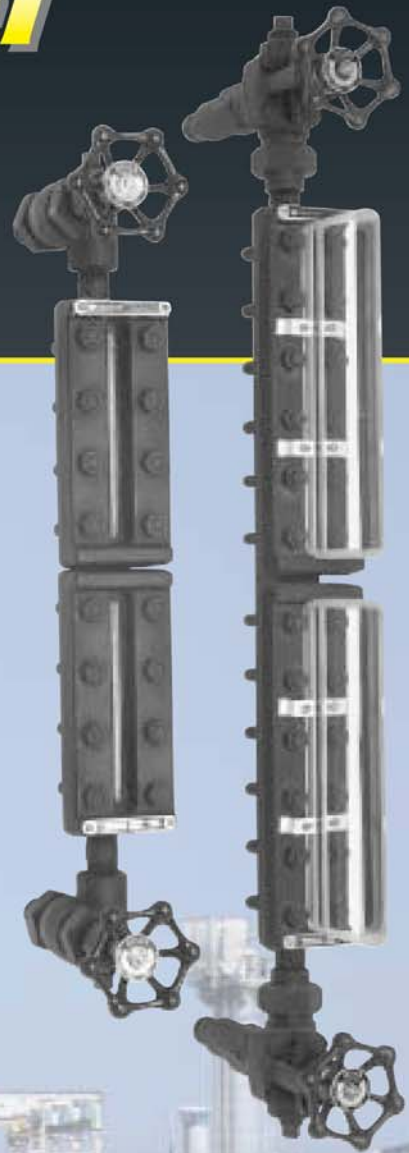

ARCHON

www.ARCHONind.com

Liquid Level Gauges



800-554-1394



ARCHON

LIQUID LEVEL GAUGES

ARCHON's quality line of Liquid Level Gauges are available in single or multiple section types. All ARCHON Gauges share the following quality features:

Standard Features:

- Carbon or 316 stainless steel one piece liquid chamber.
- Drop-forged covers that completely wrap around the sight glass.
- Tempered borosilicate glass to provide safety and reliability up to 600 degrees Fahrenheit (315 degrees Celsius).
- Recesses in the liquid chamber and the wrap around covers, for each individual sight glass and gasket, prevent internal pressure from blowing out the glass or gasket.
- High temperature steel bolts and nuts are spaced to ensure uniform pressure on the sight glasses and gaskets.
- End, Side or Back connections are available in $\frac{3}{4}$ " and $\frac{1}{2}$ " NPT

Thru-Vision Gauges:

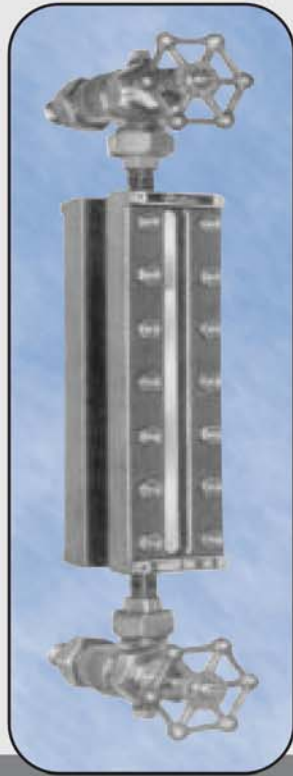

Thru-Vision Gauge

Reflex Gauges:

Using a flat reflex glass with reflecting prisms this gauge shows the liquid as black and any empty space as silver. This ensures a distinct reading of the liquid level. Large Chamber Gauges are also available.

Weld Pad Gauges:

These gauges are designed to be welded directly onto the tank where standard gauges are impractical. The standard Weld Pad Gauge is available with Thru-Vision or Reflex sight glass to indicate liquid level.

Optional Equipment:

- Frost proof sight glass extensions provide visibility in temperatures as low as minus 325 degrees Fahrenheit.
- Internal and external heating/cooling tubes are available for services where it is necessary to keep the fluids flowing freely.
- End, Side or Back connections are available with ANSI flanges or female socket weld.
- Sight glass for service temperature up to 750 degrees F.

Maximum Rating:

Thru-Vision: 2000psi @ 100° F (TM), 3000psi @ 100° F (TH)

Reflex: 3000psi @ 100° F (RM), 4000psi @ 100° F (RH)

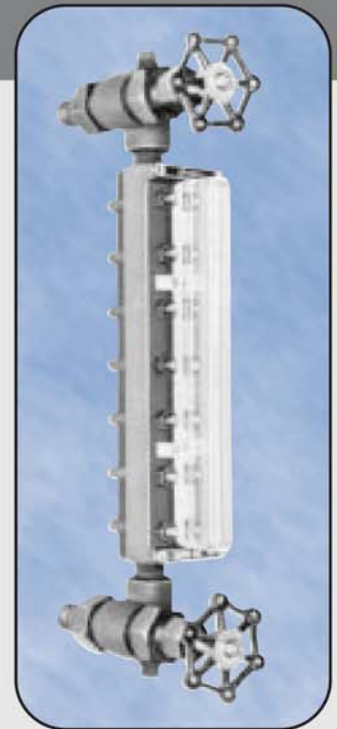

Frost-Proof Reflex Gauge



ARMORED LIQUID LEVEL GAUGES

Reflex Model RL and Transparent Model TL LOW PRESSURE FLAT GLASS GAUGES

ARCHON models RL and TL are low pressure gauges and are available in both single and multiple section types 1 through 9 with a one-piece liquid chamber. They are machined from solid bar stock of cold rolled carbon steel, stress relieved and assembled complete with drop forged steel covers, tempered borosilicate glass, gaskets, bolts and nuts, making the gauges resistant to thermal shock, heat, corrosion and abrasion.

The liquid chamber is recessed to hold each individual gauge glass and gasket snugly, eliminating any possible movement by internal pressure.

All bolts are properly spaced to ensure uniform pressure on the glass and gaskets, and are manufactured from ASTM grade steel. The gaskets used are of the finest quality, uniform in thickness and accurately die-cut. Our standard gasket material is compressed non-asbestos, but can be interchanged with alternate material depending on the liquid being used.

Gauges are also available in Stainless Steel, Monel, or other alloys.

ARCHON does not recommend low pressure gauges for steam applications.

Please review the tables below for temperature and pressure ratings..

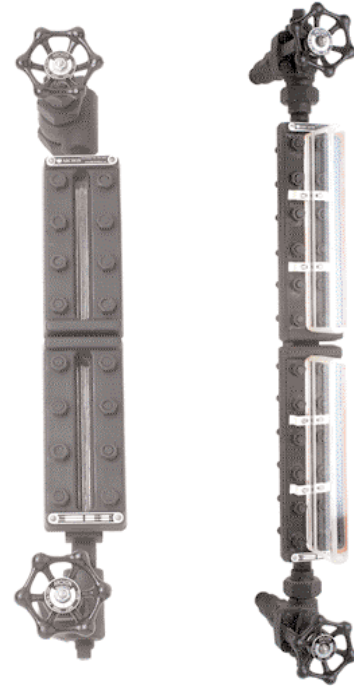

sales@ARCHONind.com

Pressure and Temperature Ratings: ARCHON Reflex Gauges Model RL						
Size Gauge	100°F	200°F	300°F	400°F	500°F	600°F
1 x 1	2400	2320	2240	2150	2000	1780
1 x 2	2325	2250	2170	2080	1940	1720
1 x 3	2250	2180	2100	2020	1880	1670
1 x 4	2175	2100	2020	1940	1820	1600
1 x 5	2100	2030	1960	1880	1750	1550
1 x 6	2025	1950	1890	1810	1680	1500
1 x 7	1950	1890	1820	1750	1630	1440
1 x 8	1875	1820	1750	1680	1560	1390
1 x 9	1800	1740	1680	1620	1510	1340

All Gauges Hydrostatic Tested: 1.5 times 100°F Rating

Pressure and Temperature Ratings: ARCHON Transparent Gauges Model TL						
Size Gauge	100°F	200°F	300°F	400°F	500°F	600°F
1 x 1	2000	1930	1870	1790	1660	1480
1 x 2	1815	1715	1690	1620	1510	1340
1 x 3	1630	1580	1520	1460	1360	1210
1 x 4	1440	1390	1340	1290	1200	1060
1 x 5	1250	1210	1170	1120	1040	920
1 x 6	1065	1030	995	950	890	790
1 x 7	875	845	815	785	730	645
1 x 8	690	665	645	620	575	510
1 x 9	500	480	465	445	415	370

All Gauges Hydrostatic Tested: 1.5 times 100°F Rating

Correction Factor Table-To be Applied to the 100% Ratings Listed Above

% of Rating	100%	75%	50%	25%
Chamber	Carbon Steel, 304SS and 316SS	Monel		
Gasket Material Liquid Side	Teflon Lo-Flo, Non-Asbestos		Pure Teflon, Kel-F Shields	
Gasket Material Liquid & Cover Side	Non-Asbestos		Teflon Lo-Flo	Pure Teflon
Optional Features	Non-Frost Extensions (Max. Temp. 100°F)			

ARMORED LIQUID LEVEL GAUGES

Reflex Model RM and Transparent Model TM

ARCHON models RM and TM are medium pressure gauges and are available in both single and multiple section types 1 through 9 with a one-piece liquid chamber. They are machined from solid bar stock of cold rolled carbon steel, stress relieved and assembled complete with drop forged steel covers, tempered borosilicate glass, gaskets, bolts and nuts, making the gauges resistant to thermal shock, heat, corrosion and abrasion.

The liquid chamber is recessed to hold each individual gauge glass and gasket snugly, eliminating any possible movement by internal pressure.

All bolts are properly spaced to ensure uniform pressure on the glass and gaskets, and are manufactured from ASTM grade steel. The gaskets used are of the finest quality, uniform in thickness and accurately die-cut. Our standard gasket material is compressed non-asbestos, but can be interchanged with alternate material depending on the liquid being used.

Gauges are also available in Stainless Steel, Monel, or other alloys.

Please review the tables below for temperature and pressure ratings..



sales@ARCHONind.com

Pressure and Temperature Ratings: ARCHON Reflex Gauges Model RM						
Size Gauge	100°F	200°F	300°F	400°F	500°F	600°F
1 x 1	3000	2800	2625	2475	2250	2000
1 x 2	2850	2700	2500	2360	2150	1900
1 x 3	2700	2600	2400	2200	2000	1800
1 x 4	2600	2450	2350	2150	1900	1750
1 x 5	2550	2400	2200	2000	1850	1600
1 x 6	2400	2250	2100	1900	1700	1500
1 x 7	2250	2100	1975	1825	1650	1450
1 x 8	2100	2000	1850	1700	1550	1350
1 x 9	2000	1900	1775	1625	1470	1300

All Gauges Hydrostatic Tested: 1.5 times 100°F Rating

Pressure and Temperature Ratings: ARCHON Transparent Gauges Model TM						
Size Gauge	100°F	200°F	300°F	400°F	500°F	600°F
1 x 1	2000	1850	1750	1650	1500	1300
1 x 2	1900	1750	1650	1500	1450	1250
1 x 3	1800	1650	1500	1400	1300	1100
1 x 4	1700	1550	1400	1300	1200	1070
1 x 5	1600	1450	1300	1200	1100	1000
1 x 6	1500	1300	1200	1100	1000	900
1 x 7	1400	1200	1100	1000	925	850
1 x 8	1300	1100	1000	900	850	750
1 x 9	1200	1050	900	800	750	650

All Gauges Hydrostatic Tested: 1.5 times 100°F Rating

Correction Factor Table-To be Applied to the 100% Ratings Listed Above

% of Rating	100%	75%	50%	25%
Chamber	Carbon Steel, 304SS and 316SS	Monel		
Gasket Material Liquid Side	Teflon Lo-Flo, Non-Asbestos		Pure Teflon, Kel-F Shields	
Gasket Material Liquid & Cover Side	Non-Asbestos		Teflon Lo-Flo	Pure Teflon
Optional Features	Non-Frost Extensions (Max. Temp. 100°F)			

ARMORED LIQUID LEVEL GAUGES

REFLEX GAUGES - This gauge type is equipped with flat reflex glass comprised of reflecting prisms which cause the liquid inside to appear black in color. The space above appears silvery in direct contrast assuring a distinct reading of the liquid level.

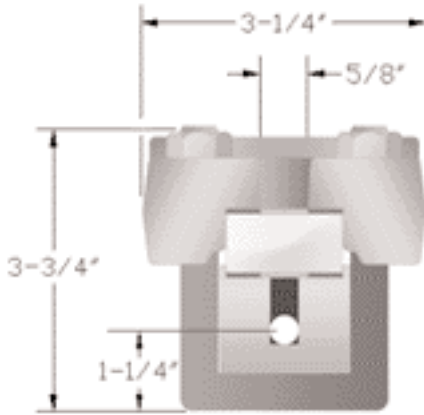

Model RL/RM Reflex

TRANSPARENT GAUGES - This gauge type is equipped with two flat plain glass sections; one on either side of the liquid chamber. This allows light to pass through the gauge permitting clear observation of liquid level, color and clarity. Plastic or MICA shields can be furnished when handling caustic substances, acids or media corrosive to glass.

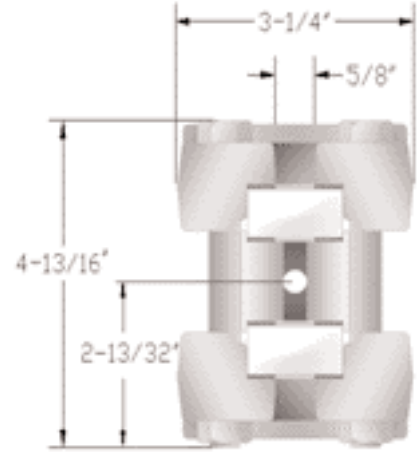

Model TL/TM Transparent

Connection styles available:
1/2" or 3/4" NPT Female with end, side or back connections.

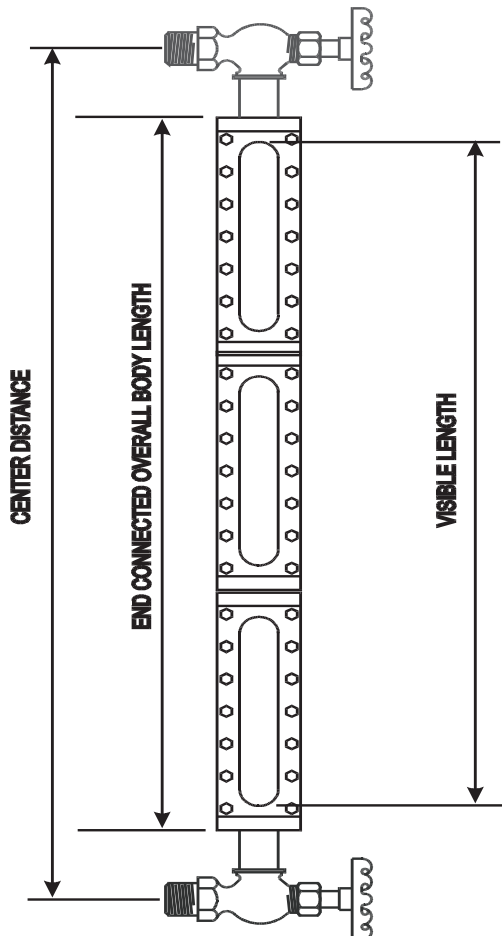

Sections	Glass Size	Visible Length		End Connected Overall Length	
		inch	mm	inch	mm
1	1	3.750	95	5.250	133
1	2	4.750	121	6.250	159
1	3	5.750	146	7.250	184
1	4	6.750	171	8.250	210
1	5	7.875	200	9.375	238
1	6	9.125	232	10.625	270
1	7	10.250	260	11.750	298
1	8	11.875	302	13.375	340
1	9	12.625	321	14.125	359
2	4	15.000	381	16.500	419
2	5	17.250	438	18.750	476
2	6	19.750	502	21.250	540
2	7	22.000	559	23.500	597
2	8	25.250	641	26.750	679
2	9	26.750	679	28.250	718
3	6	30.375	772	31.875	810
3	7	33.750	857	35.250	895
3	8	38.625	981	40.125	1019
3	9	40.875	1038	42.375	1076
4	7	45.500	1156	47.000	1194
4	8	52.000	1321	53.500	1359
4	9	55.000	1397	56.500	1435
5	7	57.250	1454	58.750	1492
5	8	65.375	1661	66.875	1699
5	9	69.125	1756	70.625	1794
6	8	78.750	2000	80.250	2038
6	9	83.250	2115	84.750	2153
7	8	92.125	2340	93.625	2378
7	9	97.375	2473	98.875	2511
8	8	105.500	2680	107.000	2718
8	9	111.500	2832	113.000	2870
9	8	118.875	3019	120.375	3058
9	9	125.625	3191	127.125	3229
10	8	132.250	3359	133.750	3397
10	9	139.750	3550	141.250	3588

sales@ARCHONind.com

ARMORED LIQUID LEVEL GAUGES

Reflex Model RH and Transparent Model TH

ARCHON models RH and TH are high pressure gauges and are available in both single and multiple section types 1 through 9 with a one-piece liquid chamber. They are machined from solid bar stock of cold rolled carbon steel, stress relieved and assembled complete with drop forged steel covers, tempered borosilicate glass, gaskets, bolts and nuts, making the gauges resistant to thermal shock, heat, corrosion and abrasion.

The liquid chamber is recessed to hold each individual gauge glass and gasket snugly, eliminating any possible movement by internal pressure.

All bolts are properly spaced to ensure uniform pressure on the glass and gaskets, and are manufactured from ASTM grade steel. The gaskets used are of the finest quality, uniform in thickness and accurately die-cut. Our standard gasket material is compressed non-asbestos, but can be interchanged with alternate material depending on the liquid being used.

Gauges are also available in Stainless Steel, Monel, or other alloys..

Please review the tables below for temperature and pressure ratings.

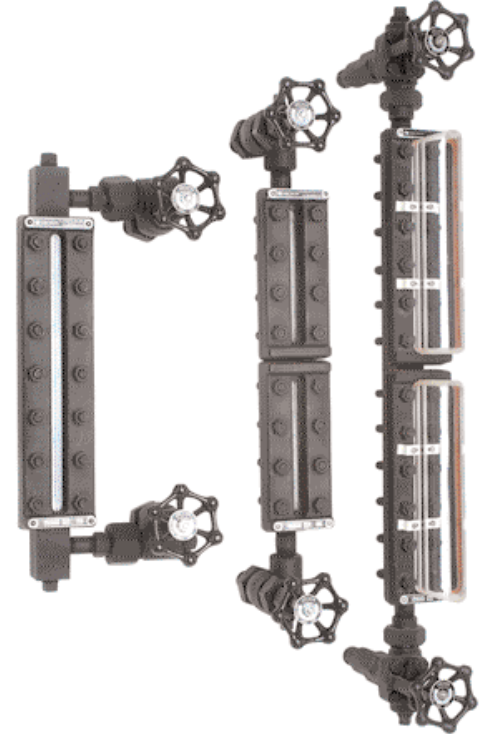

sales@ARCHONind.com

Pressure and Temperature Ratings: ARCHON Reflex Gauges Model RH						
Size Gauge	100°F	200°F	300°F	400°F	500°F	600°F
1 x 1	4000	3800	3600	3350	3100	2775
1 x 2	3850	3700	3500	3200	2950	2650
1 x 3	3700	3500	3300	3100	2850	2550
1 x 4	3600	3400	3250	3000	2750	2450
1 x 5	3450	3300	3100	2900	2650	2400
1 x 6	3300	3150	3000	2800	2550	2300
1 x 7	3200	3050	2900	2700	2450	2200
1 x 8	3100	2950	2800	2550	2350	2100
1 x 9	3000	2800	2650	2450	2250	2000

All Gauges Hydrostatic Tested: 1.5 times 100°F Rating

Pressure and Temperature Ratings: ARCHON Transparent Gauges Model TH						
Size Gauge	100°F	200°F	300°F	400°F	500°F	600°F
1 x 1	3000	2850	2750	2550	2300	2000
1 x 2	2850	2700	2550	2400	2200	1900
1 x 3	2700	2550	2400	2300	2100	1800
1 x 4	2550	2450	2300	2200	1950	1750
1 x 5	2450	2300	2200	2100	1850	1700
1 x 6	2400	2250	2100	2000	1800	1600
1 x 7	2200	2100	1950	1850	1700	1500
1 x 8	2050	1950	1800	1700	1600	1400
1 x 9	2000	1900	1750	1650	1500	1300

All Gauges Hydrostatic Tested: 1.5 times 100°F Rating

Correction Factor Table-To be Applied to the 100% Ratings Listed Above

% of Rating	100%	75%	50%	25%
Chamber	Carbon Steel, 304SS and 316SS	Monel		
Gasket Material Liquid Side	Teflon Lo-Flo, Non-Asbestos		Pure Teflon, Kel-F Shields	
Gasket Material Liquid & Cover Side	Non-Asbestos		Teflon Lo-Flo	Pure Teflon
Optional Features	Non-Frost Extensions (Max. Temp. 100°F)			

ARMORED LIQUID LEVEL GAUGES

REFLEX GAUGES - This gauge type is equipped with flat reflex glass comprised of reflecting prisms which cause the liquid inside to appear black in color. The space above appears silvery in direct contrast assuring a distinct reading of the liquid level.

TRANSPARENT GAUGES - This gauge type is equipped with two flat plain glass sections; one on either side of the liquid chamber. This allows light to pass through the gauge permitting clear observation of liquid level, color and clarity.

Plastic or MICA shields can be furnished when handling caustic substances, acids or media corrosive to glass.

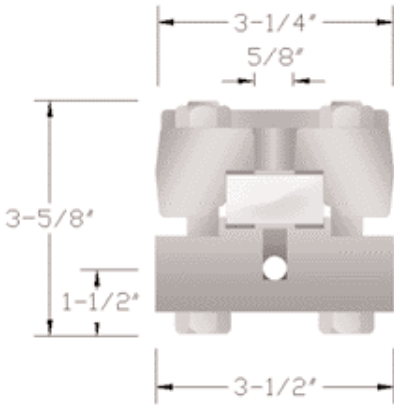

Model RH Reflex

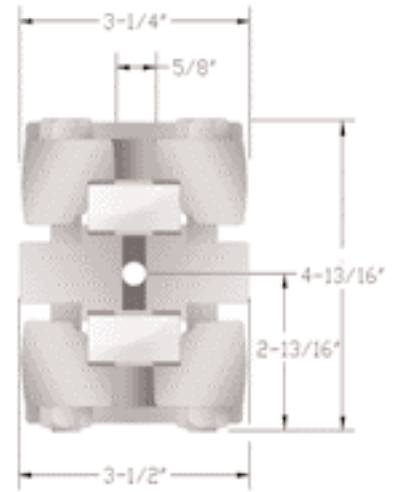

Model TH Transparent

Connection styles available:

1/2" or 3/4" NPT Female with end, side or back connections.

**5 Section Gauge
Size 9 Glass**

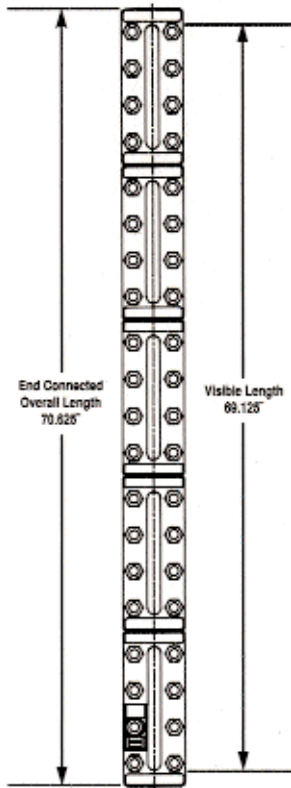

Sections	Glass Size	Visible Length		End Connected Overall Length	
		inch	mm	inch	mm
1	1	3.750	95	5.250	133
1	2	4.750	121	6.250	159
1	3	5.750	146	7.250	184
1	4	6.750	171	8.250	210
1	5	7.875	200	9.375	238
1	6	9.125	232	10.625	270
1	7	10.250	260	11.750	298
1	8	11.875	302	13.375	340
1	9	12.625	321	14.125	359
2	4	15.000	381	16.500	419
2	5	17.250	438	18.750	476
2	6	19.750	502	21.250	540
2	7	22.000	559	23.500	597
2	8	25.250	641	26.750	679
2	9	26.750	679	28.250	718
3	6	30.375	772	31.875	810
3	7	33.750	857	35.250	895
3	8	38.625	981	40.125	1019
3	9	40.875	1038	42.375	1076
4	7	45.500	1156	47.000	1194
4	8	52.000	1321	53.500	1359
4	9	55.000	1397	56.500	1435
5	7	57.250	1454	58.750	1492
5	8	65.375	1661	66.875	1699
5	9	69.125	1756	70.625	1794
6	8	78.750	2000	80.250	2038
6	9	83.250	2115	84.750	2153
7	8	92.125	2340	93.625	2378
7	9	97.375	2473	98.875	2511
8	8	105.500	2680	107.000	2718
8	9	111.500	2832	113.000	2870
9	8	118.875	3019	120.375	3058
9	9	125.625	3191	127.125	3229
10	8	132.250	3359	133.750	3397
10	9	139.750	3550	141.250	3588

sales@ARCHONind.com

ARMORED LIQUID LEVEL GAUGES

Large Chamber Gauges Model RLC and TLC

ARCHON models RLC and TLC are designed to give a more accurate reading for liquids that have a tendency to surge or boil, than could be achieved with the standard gauges.

Here are some of the qualities that make ARCHON armored gauges superior to our competitors gauges:

- The liquid chamber is made from exceptionally heavy tubing 2" ID x 3-3/4"OD with a 7/8" wall thickness.
- The liquid chamber is recessed to hold each individual gauge glass and gasket snugly, eliminating any possible movement by internal pressure.
- The covers are fitted to the liquid chamber with stud bolts, making assembly or replacement of glasses and gaskets much easier and faster than with curved U-bolts and through bolts.

The covers are drop forged, machined to fit the contour of the glass and provides full support for the front cushion gasket. It is bolted to the face of the liquid chamber with the glass and gaskets in between.

Gaskets used are of the finest quality, uniform in thickness and accurately die-cut. Our standard gasket material is compressed non-asbestos, but can be interchanged with alternate material depending on the liquid being used.

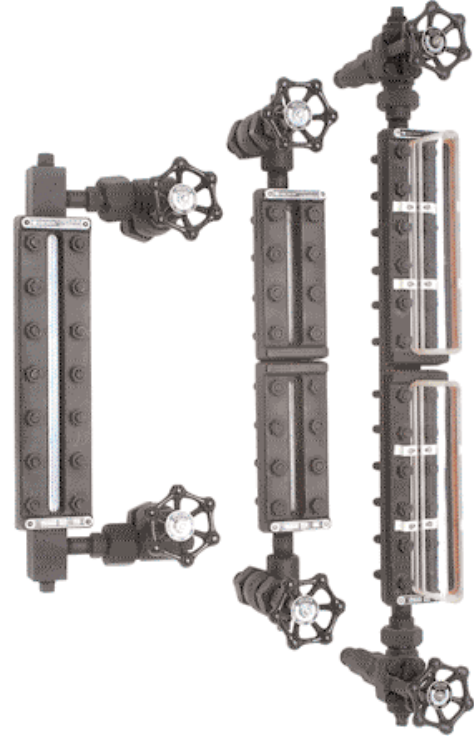

sales@ARCHONind.com

Pressure and Temperature Ratings: ARCHON Reflex Gauges Model RLC						
Size Gauge	100°F	200°F	300°F	400°F	500°F	600°F
1 x 1	2000	1900	1850	1750	1550	1300
1 x 2	1950	1850	1750	1600	1450	1270
1 x 3	1900	1800	1700	1550	1400	1250
1 x 4	1850	1750	1650	1500	1350	1220
1 x 5	1800	1700	1600	1450	1300	1200
1 x 6	1750	1650	1550	1400	1250	1170
1 x 7	1700	1600	1500	1350	1200	1150
1 x 8	1600	1500	1400	1300	1150	1100
1 x 9	1500	1400	1350	1250	1100	1050

All Gauges Hydrostatic Tested: 1.5 times 100°F Rating

Pressure and Temperature Ratings: ARCHON Transparent Gauges Model TLC						
Size Gauge	100°F	200°F	300°F	400°F	500°F	600°F
1 x 1	1500	1400	1300	1150	1000	850
1 x 2	1450	1350	1250	1100	970	830
1 x 3	1400	1300	1200	1070	940	800
1 x 4	1350	1250	1150	1040	900	770
1 x 5	1300	1200	1100	1000	870	750
1 x 6	1250	1150	1050	950	830	720
1 x 7	1200	1100	1000	900	800	700
1 x 8	1100	1050	950	850	750	650
1 x 9	1000	950	850	750	650	550

All Gauges Hydrostatic Tested: 1.5 times 100°F Rating

Correction Factor Table-To be Applied to the 100% Ratings Listed Above

% of Rating	100%	75%	50%	25%
Chamber	Carbon Steel, 304SS and 316SS	Monel	Bronze	
Gasket Material Liquid Side	Teflon Lo-Flo, Non-Asbestos		Pure Teflon, Kel-F Shields	
Gasket Material Liquid & Cover Side	Non-Asbestos		Teflon Lo-Flo	Pure Teflon
Optional Features	Non-Frost Extensions (Max. Temp. 100°F)			

ARMORED LIQUID LEVEL GAUGES

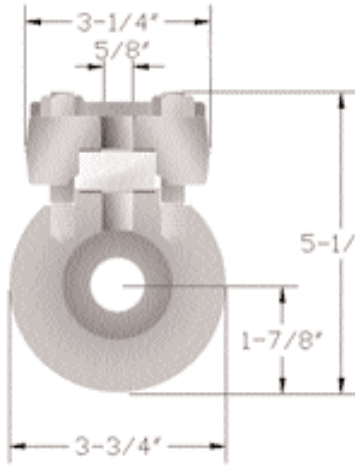

**ARCHON Model RLC
Large Chamber Unit**

We can furnish these gauges in single section sizes 1 through 9 or in multiple section type with one-piece liquid chamber for the entire length of the gauge.

The liquid chamber can be supplied in Steel or Stainless Steel to meet specific requirements.

REFLEX GAUGES - This gauge type is equipped with flat reflex glass comprised of reflecting prisms which cause the liquid inside to appear black in color. The space above appears silvery in direct contrast assuring a distinct reading of the liquid level.

TRANSPARENT GAUGES - This gauge type is equipped with two flat plain glass sections; one on either side of the liquid chamber. This allows light to pass through the gauge permitting clear observation of liquid level, color and clarity.

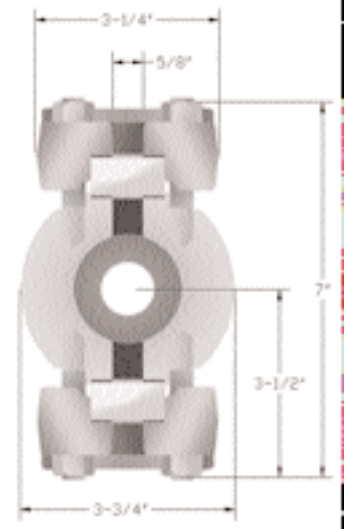

**ARCHON Model TLC
Large Chamber Unit**

Plastic or MICA shields can be furnished when handling caustic substances, acids or media corrosive to glass.

**5 Section Gauge
Size 9 Glass**

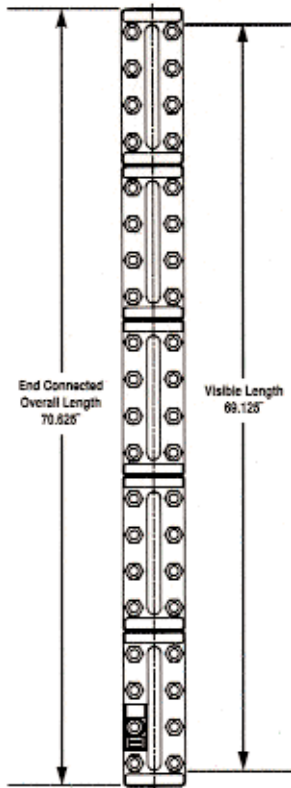

Sections	Glass Size	Visible Length		End Connected Overall Length	
		inch	mm	inch	mm
1	1	3.750	95	5.250	133
1	2	4.750	121	6.250	159
1	3	5.750	146	7.250	184
1	4	6.750	171	8.250	210
1	5	7.875	200	9.375	238
1	6	9.125	232	10.625	270
1	7	10.250	260	11.750	298
1	8	11.875	302	13.375	340
1	9	12.625	321	14.125	359
2	4	15.000	381	16.500	419
2	5	17.250	438	18.750	476
2	6	19.750	502	21.250	540
2	7	22.000	559	23.500	597
2	8	25.250	641	26.750	679
2	9	26.750	679	28.250	718
3	6	30.375	772	31.875	810
3	7	33.750	857	35.250	895
3	8	38.625	981	40.125	1019
3	9	40.875	1038	42.375	1076
4	7	45.500	1156	47.000	1194
4	8	52.000	1321	53.500	1359
4	9	55.000	1397	56.500	1435
5	7	57.250	1454	58.750	1492
5	8	65.375	1661	66.875	1699
5	9	69.125	1756	70.625	1794
6	8	78.750	2000	80.250	2038
6	9	83.250	2115	84.750	2153
7	8	92.125	2340	93.625	2378
7	9	97.375	2473	98.875	2511
8	8	105.500	2680	107.000	2718
8	9	111.500	2832	113.000	2870
9	8	118.875	3019	120.375	3058
9	9	125.625	3191	127.125	3229
10	8	132.250	3359	133.750	3397
10	9	139.750	3550	141.250	3588

ARMORED LIQUID LEVEL GAUGES

ARCHON model RLG and TLG Weld Pad Type Gauges

ARCHON Weld Pad Gauges are designed to be welded directly to a tank or other liquid-containing vessels. The body lengths and visibility are the same as standard gauges in single or multiple section type. These gauges consist of a pad which is machined from bar stock 3 1/2" wide, standard forged covers, glass, gaskets & bolts.

The model RLG with Reflex Glass is used where only the reading of the liquid level is desired.

The model TLG with Transparent Glass is used where the installation is made on each side of the vessel for look through visibility.

The Weld Pad is normally furnished flat but can be machined to fit the contour of the vessel.

The Pad material can be Carbon Steel, Stainless Steel or other specified Alloys.

The standard cover is Forged Steel but other Alloys are available.

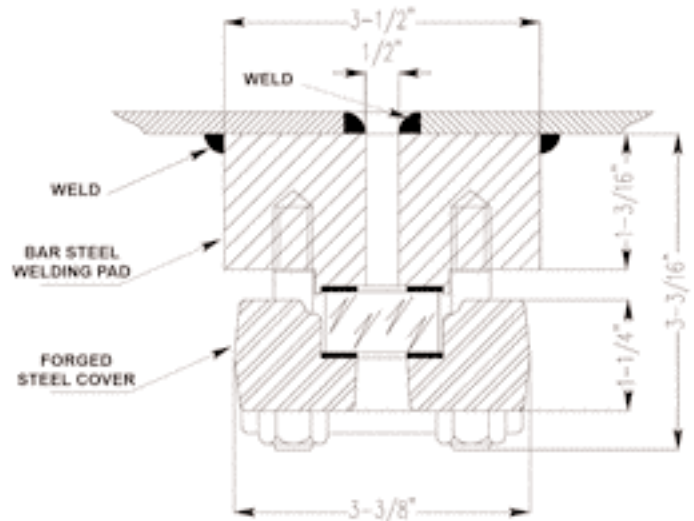

RLG / TLG Model	Sections	Glass Size	Visible Length, V		Overall Length, L	
			inch	mm	inch	mm
1 x 1	1	1	3 3/4	95	5 1/4	133
1 x 2	1	2	4 3/4	121	6 1/4	159
1 x 3	1	3	5 3/4	146	7 1/4	184
1 x 4	1	4	6 3/4	171	8 1/4	210
1 x 5	1	5	7 7/8	200	9 3/8	238
1 x 6	1	6	9 1/8	232	10 5/8	270
1 x 7	1	7	10 1/4	260	11 3/4	298
1 x 8	1	8	11 7/8	302	13 3/8	340
1 x 9	1	9	12 5/8	321	14 1/8	359
2 x 4	2	4	15	381	16 1/2	419
2 x 5	2	5	17 1/4	438	18 3/4	476
2 x 6	2	6	19 3/4	502	21 1/4	540
2 x 7	2	7	22	559	23 1/2	597
2 x 8	2	8	25 1/4	641	26 3/4	679
2 x 9	2	9	26 3/4	679	28 1/4	718
3 x 6	3	6	30 3/8	772	31 7/8	810
3 x 7	3	7	33 3/4	857	35 1/4	895
3 x 8	3	8	38 5/8	981	40 1/8	1019
3 x 9	3	9	40 7/8	1038	42 3/8	1076
4 x 7	4	7	45 1/2	1156	47	1194
4 x 8	4	8	52	1321	53 1/2	1359
4 x 9	4	9	55	1397	56 1/2	1435
5 x 7	5	7	57 1/4	1454	58 3/4	1492
5 x 8	5	8	65 3/8	1661	66 7/8	1699
5 x 9	5	9	69 1/8	1756	70 5/8	1794

sales@ARCHONind.com

ARMORED LIQUID LEVEL GAUGES

VESSEL CENTERS for ARCHON REFLEX and TRANSPARENT GAUGES

(Dimensions listed in the table below show the minimum distance permissible for each gauge and gauge cock assembly.)

Choose the type gauge and gauge cocks desired according to the pressure and temperature ratings.

Minimum Distance between Gauge Cock Centers in inches

Size	Body Length	Visibility	End Connected with Nipples	Union End Connected with Nipples	Standard Close Hook-up	Offset Close Hook-up (Offset Inside)	Offset Close Hook-up (Offset Outside)
			Gauge Cocks BB-101*** 705, 706, 905, 906	Gauge Cocks BB-121** 725, 726, 925, 926	*Without Gauge Cocks	* Gauge Cocks 700 & 900 Series BB-100 Series	* Gauge Cocks 700 & 900 Series BB-100 Series
1x1	5 1/4"	3 3/4"	8 3/4"	11 1/8"	5 1/4"	3 1/2"	7"
1x2	6 1/4"	4 3/4"	9 3/4"	12 1/8"	6 1/4"	4 1/2"	8"
1x3	7 1/4"	5 3/4"	10 3/4"	13 1/8"	7 1/4"	5 1/2"	9"
1x4	8 1/4"	6 3/4"	11 3/4"	14 1/8"	8 1/4"	6 1/2"	10"
1x5	9 3/8"	7 7/8"	12 7/8"	15 1/4"	9 3/8"	7 5/8"	11 1/8"
1x6	10 5/8"	9 1/8"	14 1/8"	16 1/2"	10 5/8"	8 7/8"	12 3/8"
1x7	11 3/4"	10 1/4"	15 1/4"	17 5/8"	11 3/4"	10"	13 1/2"
1x8	13 3/8"	11 7/8"	16 7/8"	19 1/4"	13 3/8"	11 5/8"	15 1/8"
1x9	14 1/8"	12 5/8"	17 5/8"	20"	14 1/8"	12 3/8"	15 7/8"
2x4	16 1/2"	15"	20"	22 3/8"	16 1/2"	14 3/4"	18 1/4"
2x5	18 3/4"	17 1/4"	22 1/4"	24 5/8"	18 3/4"	17"	20 1/2"
2x6	21 1/4"	19 3/4"	24 3/4"	27 1/8"	21 1/4"	19 1/2"	23"
2x7	23 1/2"	22"	27"	29 3/8"	23 1/2"	21 3/4"	25 1/4"
2x8	26 3/4"	25 1/4"	30 1/4"	32 5/8"	26 3/4"	25"	28 1/2"
2x9	28 1/4"	26 3/4"	31 3/4"	34 1/8"	28 1/4"	26 1/2"	30"
3x6	31 7/8"	30 3/8"	35 3/8"	37 3/4"	31 7/8"	30 1/8"	33 5/8"
3x7	35 1/4"	33 3/4"	38 3/4"	41 1/8"	35 1/4"	33 1/2"	37"
3x8	40 1/8"	38 5/8"	43 5/8"	46"	40 1/8"	38 3/8"	41 7/8"
3x9	42 3/8"	40 7/8"	45 7/8"	48 1/4"	42 3/8"	40 5/8"	44 1/8"
4x7	47"	45 1/2"	50 1/2"	52 7/8"	47"	45 1/4"	48 3/4"
4x8	53 1/2"	52"	57"	59 3/8"	53 1/2"	51 3/4"	55 1/4"
4x9	56 1/2"	55"	60"	62 3/8"	56 1/2"	54 3/4"	58 1/4"
5x7	58 3/4"	57 1/4"	62 1/4"	64 5/8"	58 3/4"	57"	60 1/2"
5x8	66 7/8"	65 3/8"	70 3/8"	72 3/4"	66 7/8"	65 1/8"	68 5/8"
5x9	70 5/8"	69 1/8"	74 1/8"	76 1/2"	70 5/8"	68 7/8"	72 3/8"
6x8	80 1/4"	78 3/4"	83 3/4"	86 1/8"	80 1/4"	78 1/2"	82"
6x9	84 3/4"	83 1/4"	88 1/4"	90 5/8"	84 3/4"	83"	86 1/2"
7x8	93 5/8"	92 1/8"	97 1/8"	99 1/2"	93 5/8"	91 7/8"	95 3/8"
7x9	98 7/8"	97 3/8"	102 3/8"	104 3/4"	98 7/8"	97 1/8"	100 5/8"
8x8	107"	105 1/2"	110 1/2"	112 7/8"	107"	105 1/4"	108 3/4"
8x9	113"	111 1/2"	116 1/2"	118 7/8"	113"	111 1/4"	114 3/4"
9x8	120 3/8"	118 7/8"	123 7/8"	126 1/4"	120 3/8"	118 5/8"	122 1/8"
9x9	127 1/8"	125 5/8"	130 5/8"	133"	127 1/8"	125 3/8"	128 7/8"
10x8	133 3/4"	132 1/4"	137 1/4"	139 5/8"	133 3/4"	132"	135 1/2"
10x9	141 1/4"	139 3/4"	144 3/4"	147 1/8"	141 1/4"	139 1/2"	143"

* On Transparent gauges with back tapings: Add 1-1/2" to dimension listed.

** Add 1/2" to dimension listed.

*** Add 1" to dimension listed.

ARMORED LIQUID LEVEL GAUGES

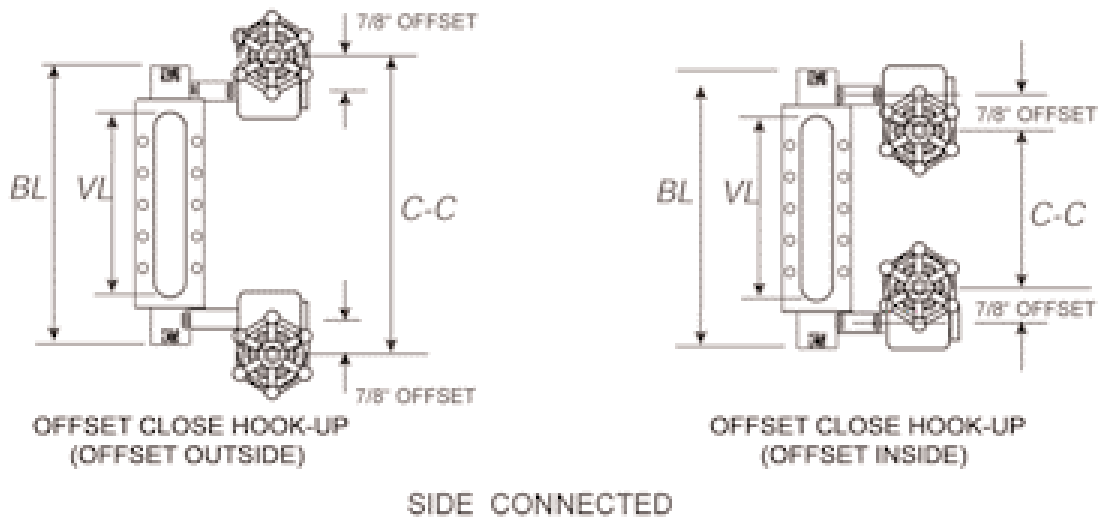
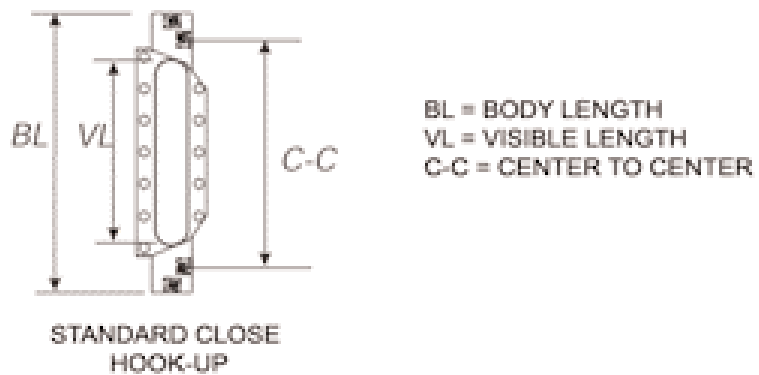
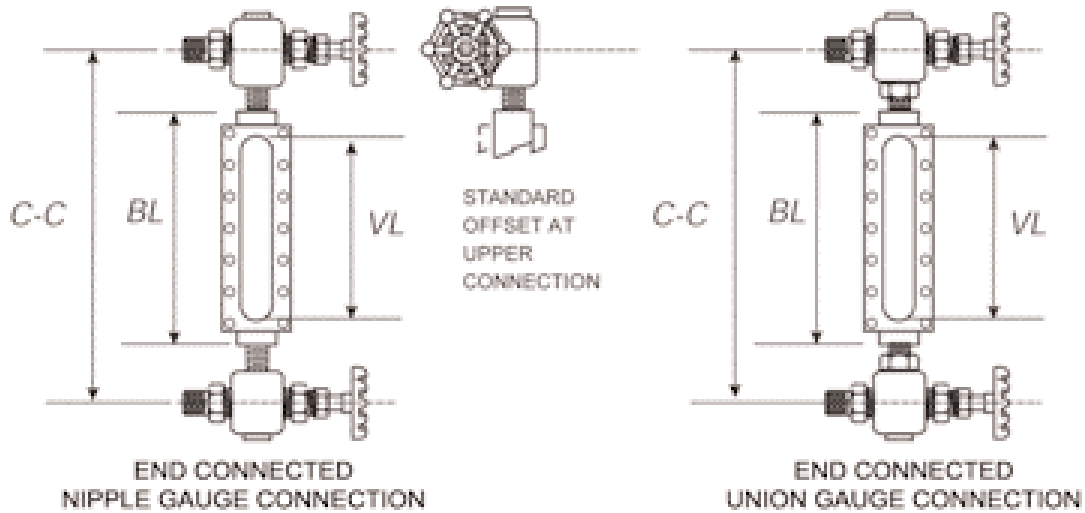

sales@ARCHONind.com

ARMORED LIQUID LEVEL GAUGES

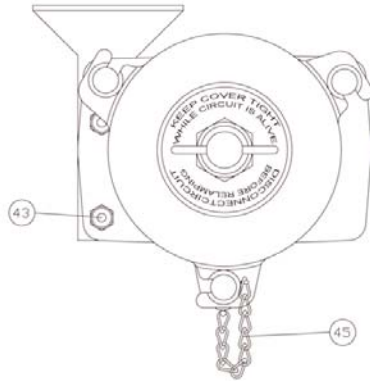

ARCHON Ex Light

For Hazardous Areas

Model XPI-20 - UL Approved

The ARCHON model XPI-20 distributes a uniform, bright light throughout the entire length of visible glass by means of a solid plastic wedge.

Lighting Fixtures for use in Hazardous Locations. Model XPI-20 Electric Gauge Illuminator for use in Hazardous Locations

**CLASS 1, GROUPS B, C, & D.
UL APPROVED**

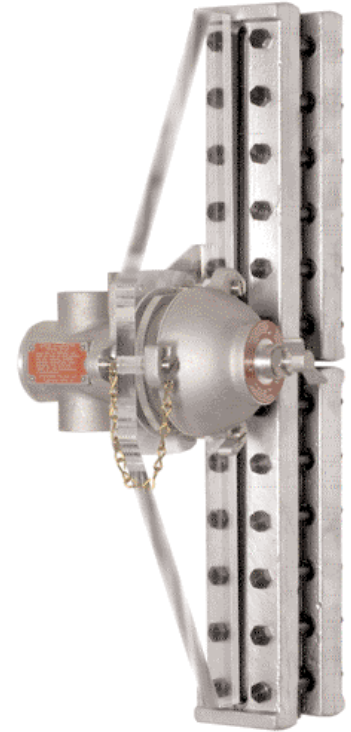

sales@ARCHONind.com

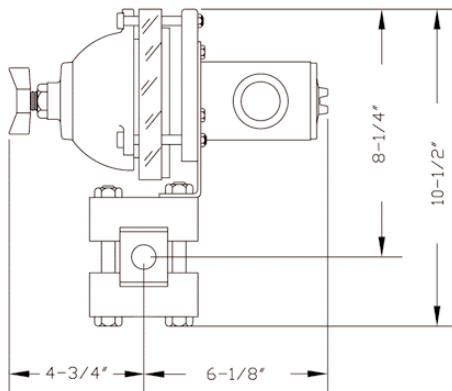
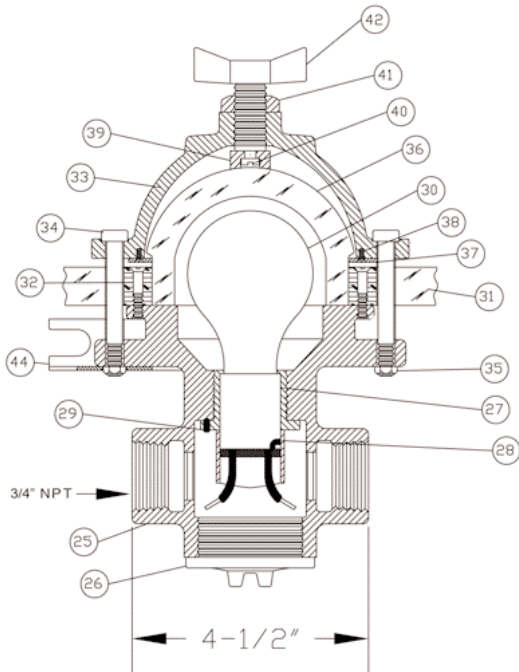

PART NO.	PART NAME
25	Housing
26	Housing Cover
27	Lamp Socket
28	Socket Housing
29	Socket Housing LK Screw
30	Lamp 58W-120V
31	Plastic Reflector
32	Reflector Screw
33	Dome Cover
34	Dome Cover Screw
35	Elastic Stop Nut
36	Dome
37	Dome Retainer
38	Retainer Screw
39	Dome Cup Washer
40	Shoulder Screw
41	Jam Nut
42	Thumb Screw
43	Bracket Cap Screw
44	Bracket
45	Chain Assembly

ARMORED LIQUID LEVEL GAUGES

HEATED or COOLED GAUGES

Internal Tube - Model IHT & External Tube Model H

Gauge Cocks - Offset - Model H

sales@ARCHONind.com

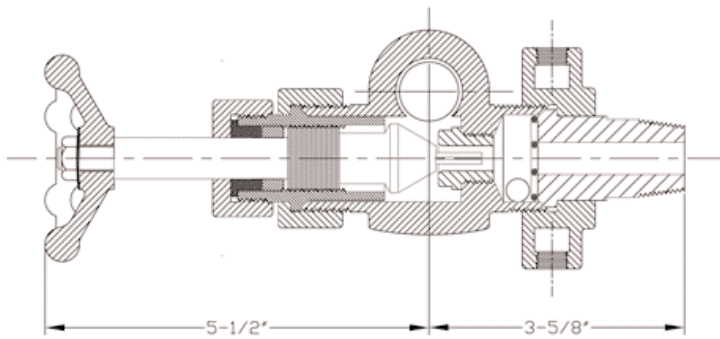
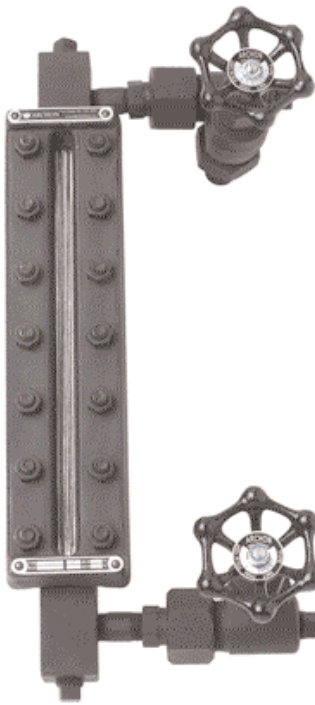

ARCHON Heated Gauges and Gauge Cocks are designed to meet certain conditions where heating is necessary to keep liquids flowing more freely to provide an accurate reading of the liquid level.

They are available in two configurations, internal and external tube. The internal type has a tube running through the liquid chamber and heats the liquid by direct contact. The External type has a tube attached to the outside of the chamber through which the heating medium can travel.

For Reflex models the heating tube is attached to the back of the liquid chamber. For Transparent models the tubes are attached to either one or both sides of the liquid chamber. The Heated Gauge Cocks have a jacket union nut for circulating the heating or cooling medium. The jacket has four 1/4" tapped holes for required heating or cooling connections.

Contact ARCHON for specific application needs.

Custom designs are always available.

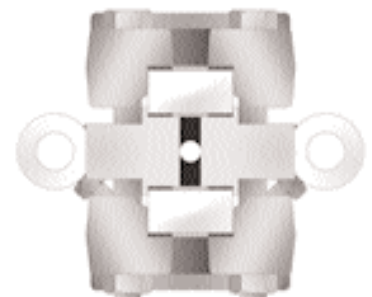
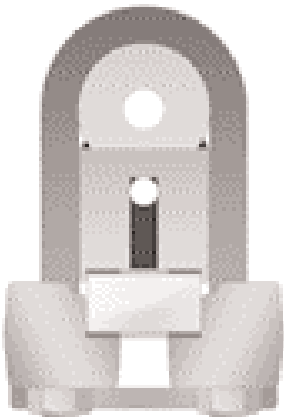

ARMORED LIQUID LEVEL GAUGES

FROST PROOF GAUGES

Available on: Reflex Models
Transparent Models
Large Chamber Reflex and Transparent Models

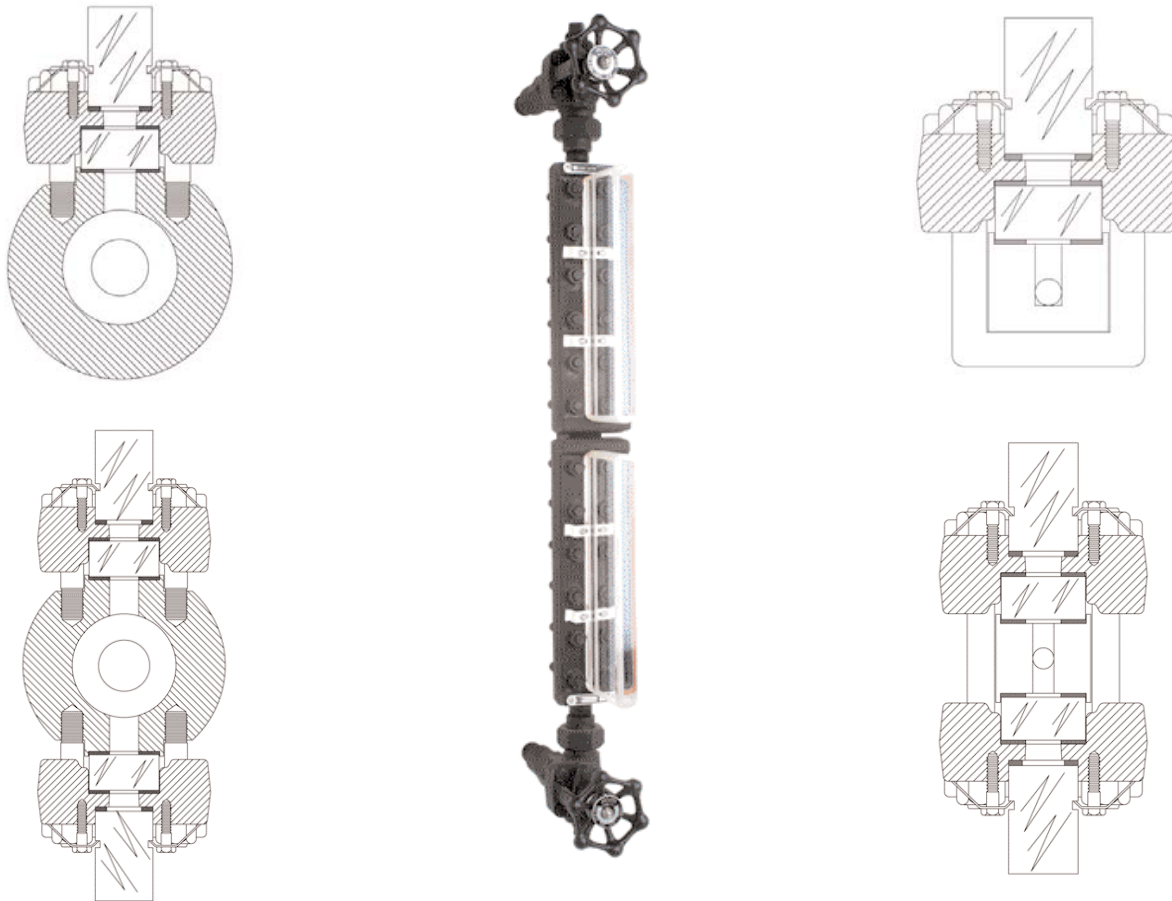

Frost Proof Gauges are used extensively in the chemical, petroleum and other processing industries where low temperatures are involved. The plastic extension projects beyond the cover so that the frost cannot build up or accumulate in the visibility slot and obscure reading of the liquid level. The extension can be furnished 2" thru 6" above the cover as required.

Temperature range between -20°F to -150°F - Bar Stock Chamber -Stainless Steel
Covers-3 1/2% Nickel Steel, ASTM spec
Bolts & Nuts - Stainless Steel

Temperature range -150°F to -325°F - All metal parts - Stainless Steel

ARMORED LIQUID LEVEL GAUGES

GAUGE MEASURING SCALES

ARCHON's measuring scale, as shown here, is manufactured from zinc alloy and is 1/8" x 2" wide. Numerals and graduations are raised 1/32", are sharp edged and clean cut.

The scale is mounted on a 1/4" thick backing and furnished with adjustable brackets. Numerals and graduations are easily read with foot numeral inserts which are bright chrome plated for contrast.

Scales are typically supplied from 0 to 11 in 1/8" increment graduations, but can also be supplied in the reverse style.

Alternate material choices are laminated plastic (Black on White or White on Black), Aluminum or Stainless Steel.

Scales are also available in metric measurements - centimeters and millimeters.

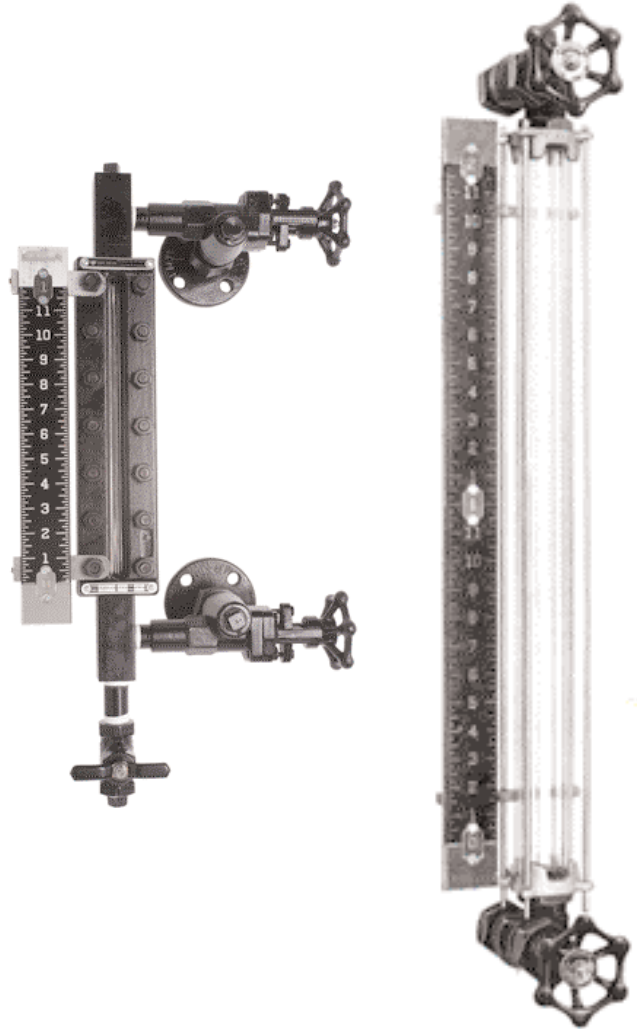

sales@ARCHONind.com

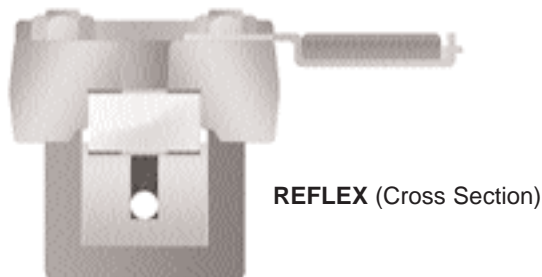
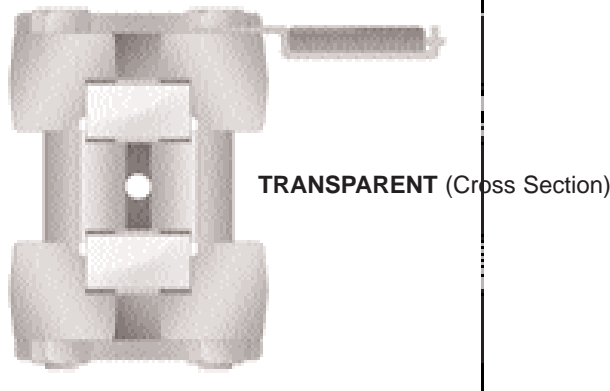

Tubular Gauge with Guard Rods and Scales

Tubular gauges are also available with special bracket arrangements for use with ARCHON gauges using our Model SGP-18 Round Plastic Guards.

ARMORED LIQUID LEVEL GAUGES

ARCHON BB-100 Series O.S. & Y Gauge Cocks Bolted Bonnet, O.S. & Y Construction

ARCHON forged steel Outside Screw and Yoke (O.S. & Y) bolted bonnet gauge cocks, offset type, have a forged yoke and a separate follower packing gland to compress the stem packing. This design places the threaded portion of the valve stem outside the valve body to prevent contact with the process fluid. The valve stem is a non-rotating reciprocating stem. It slides to and from the valve seat with a non-rotating action, which allows for perfect seating and eliminates the possibility of galling at the valve seat. The valve stem is furnished with a backseating feature to permit the repacking of the valve stem packing while the valve is in service and under pressure. These gauge cocks are furnished with renewable seats and with or without stainless steel ball checks.



PIPING CONNECTIONS:

Gauge Cocks can be furnished with 1/2" or 3/4" NPT, or Flanged.

RATING:

3000 psig at 100°F or 1500 psig at 600°F

Materials of Construction

Standard Construction	Steel	316 SS
Body Forging	Steel	316L
Bonnet Forging	Steel	316
Stem and Seat	416SS	316

- Optional Trim-316SS Stem and Seat
- Standard Packing
 - Non-Asbestos Valve Stem Packing
 - Stainless Steel-Grafoil Spirotallic Gasket
- Optional Packing
 - Teflon Valve Stem Packing
 - Stainless Steel-Teflon Spirotallic Gasket

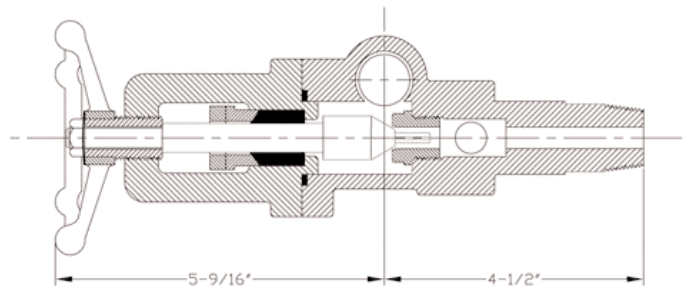

Optional Connections to Gauge

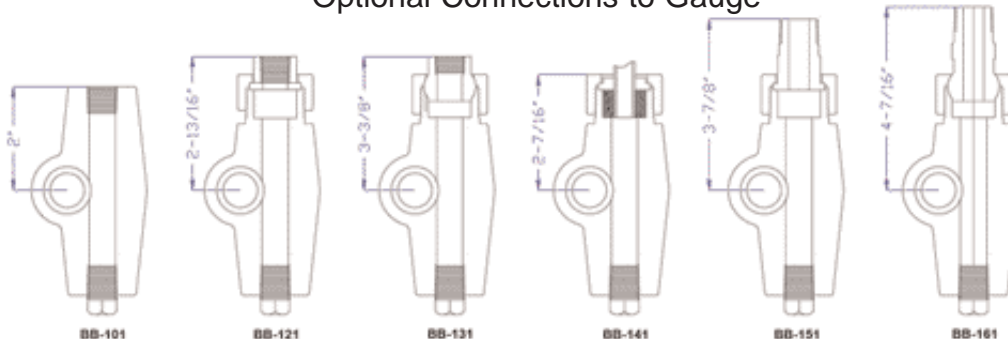

sales@ARCHONind.com

ARMORED LIQUID LEVEL GAUGES

ARCHON series 700 - OFFSET, INTEGRAL BONNET GAUGE COCKS

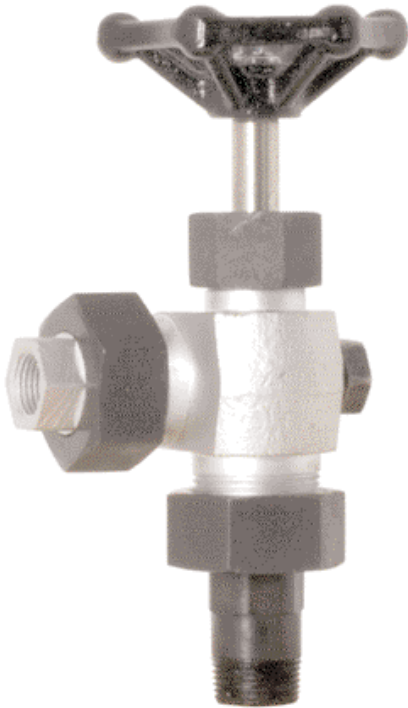
MODEL NO. 725

ARCHON's series 700 gauge cocks have drop forged steel bodies with stainless steel trim, a threaded renewable seat and safety ball checks allowing the flow to automatically shut off, should the glass break. The ball may be omitted upon request. Various connection styles are available to accommodate most pipe requirements.

The special offset feature was designed to allow easy cleaning of the inside of the gauge. The drain and vent connections are directly aligned with the gauge chamber and are offset 7/8" from the center line of the vessel connection. It is possible to clean the inside of an end connected gauge through the drain and vent connections without removing the gauge from service.

The union gauge connections make it possible to turn the gauge to any desired angle for the most convenient visibility. The union vessel connections provide access to the ball check. Gauge cocks are typically furnished with handwheel operation, but can also be supplied with a lever.

MODEL NO. 705

PRESSURE RATINGS

4000 psig at 100°F or 1700 psig at 600°F.

Exception: Model 745 (stuffing box) 1000 psig at 100°F.

STANDARD CONNECTIONS

Gauge: 1/2" NPT Female
Vessel: 3/4" NPT Male
Drain/Vent: 1/2" NPT Female

OPTIONAL CONNECTIONS

Gauge: 3/4" NPT Female
 1/2" or 3/4" NPT Male Union
 1/2" or 3/4" NPT Female Union

Vessel: 1/2" or 3/4" NPT Male Union
 1/2" or 3/4" NPT Female Union

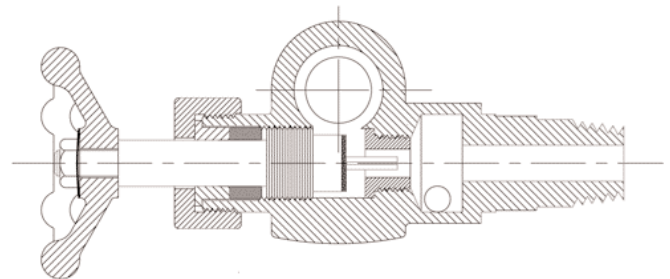

sales@ARCHONind.com

ARMORED LIQUID LEVEL GAUGES

OPTIONAL CONNECTIONS TO VESSEL

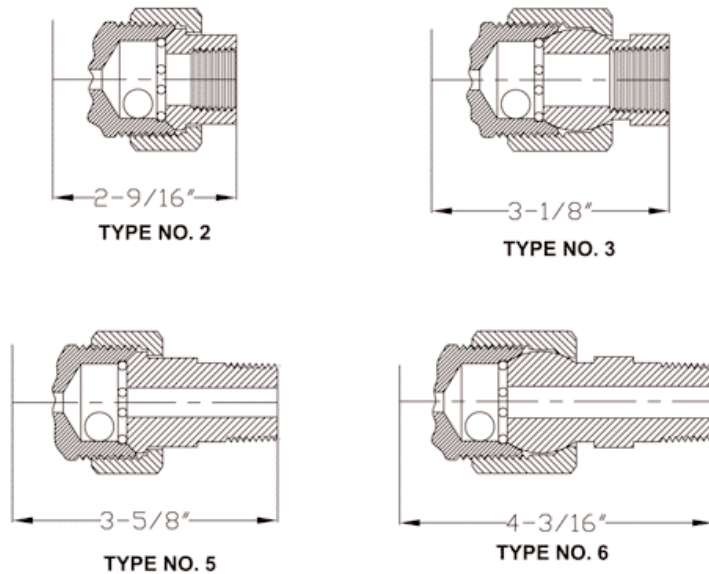

Gauge Cock models 751 thru 766 are NOT recommended for END CONNECTED GAUGES.

First Numeral: Indicates Type of Gauge Cock
 Second Numeral: Indicates Type of Connection to Gauge
 Third Numeral: Indicates Type of Connection to Vessel

Model Number	Connections to Gauge	Connections to Vessel
702	1/2" or 3/4" NPT Female	1/2" or 3/4" NPT Female Union
703	1/2" or 3/4" NPT Female	1/2" NPT Female Spherical Union
705	1/2" or 3/4" NPT Female	1/2" or 3/4" NPT Male Union
706	1/2" or 3/4" NPT Female	1/2" or 3/4" NPT Male Spherical Union
721	1/2" or 3/4" NPT Female Union	1/2" or 3/4" NPT Male Non-Union Solid Shank
722	1/2" or 3/4" NPT Female Union	1/2" or 3/4" NPT Female Union
723	1/2" or 3/4" NPT Female Union	1/2" NPT Female Spherical Union
725	1/2" or 3/4" NPT Female Union	1/2" or 3/4" NPT Male Union
726	1/2" or 3/4" NPT Female Union	1/2" or 3/4" NPT Male Spherical Union
731	1/2" NPT Female Spherical Union	1/2" or 3/4" NPT Male Non-Union Solid Shank
732	1/2" NPT Female Spherical Union	1/2" or 3/4" NPT Female Union
733	1/2" NPT Female Spherical Union	1/2" NPT Female Spherical Union
735	1/2" NPT Female Spherical Union	1/2" or 3/4" NPT Male Union
736	1/2" NPT Female Spherical Union	1/2" or 3/4" NPT Male Spherical Union
745	1/2", 5/8", 3/4" Stuffing Box	1/2" or 3/4" NPT Male Union
751	1/2" or 3/4" NPT Male Union	1/2" or 3/4" NPT Male Non-Union Solid Shank
752	1/2" or 3/4" NPT Male Union	1/2" or 3/4" NPT Female Union
753	1/2" or 3/4" NPT Male Union	1/2" NPT Female Spherical Union
755	1/2" or 3/4" NPT Male Union	1/2" or 3/4" NPT Male Union
756	1/2" or 3/4" NPT Male Union	1/2" or 3/4" NPT Male Spherical Union
761	1/2" or 3/4" NPT Male Spherical Union	1/2" or 3/4" NPT Male Non-Union Solid Shank
762	1/2" or 3/4" NPT Male Spherical Union	1/2" or 3/4" NPT Female Union
763	1/2" or 3/4" NPT Male Spherical Union	1/2" NPT Female Spherical Union
765	1/2" or 3/4" NPT Male Spherical Union	1/2" or 3/4" NPT Male Union
766	1/2" or 3/4" NPT Male Spherical Union	1/2" or 3/4" NPT Male Spherical Union

OPTIONAL CONNECTIONS TO GAUGE

Types of Connections

- 0-Threaded Connection
- 1-Female Union Connections
- 2-Female Spherical Union Connections
- 3-Stuffingbox Connections
- 4-Male Union Connections
- 5-Male Spherical Union Connections

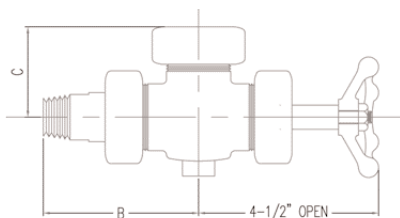

Dimension 'B': See Optional Connections to Vessel
 Dimension 'C': See Optional Connections to Gauge

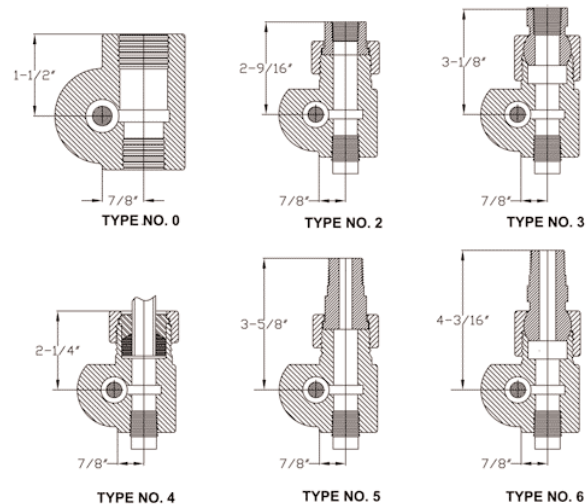

sales@ARCHONind.com

ARMORED LIQUID LEVEL GAUGES

ARCHON series 900 - OFFSET, UNION BONNET GAUGE COCKS

MODEL NO. 925

ARCHON's series 900 gauge cocks have drop forged steel bodies with stainless steel trim, a threaded renewable seat, union bonnet and safety ball checks allowing the flow to automatically shut off, should the glass break. The ball may be omitted upon request. The 900 series gauge cocks are quick closing and are equipped with backseating stems to allow repacking while under pressure. This backs out the stem to its limit so the knob on the end of the stem seats against the sleeve which stops fluid from reaching the packing. Various connection styles are available to accommodate most pipe requirements.

The special offset feature was designed to allow easy cleaning of the inside of the gauge. The drain and vent connections are directly aligned with the gauge chamber and are offset 7/8" from the center line of the vessel connection. It is possible to clean the inside of an end connected gauge through the drain and vent connections without removing the gauge from service.

The union gauge connections make it possible to turn the gauge to any desired angle for the most convenient visibility. The union vessel connections provide access to the ball check. Gauge cocks are typically furnished with handwheel operation, but can also be supplied with a lever.

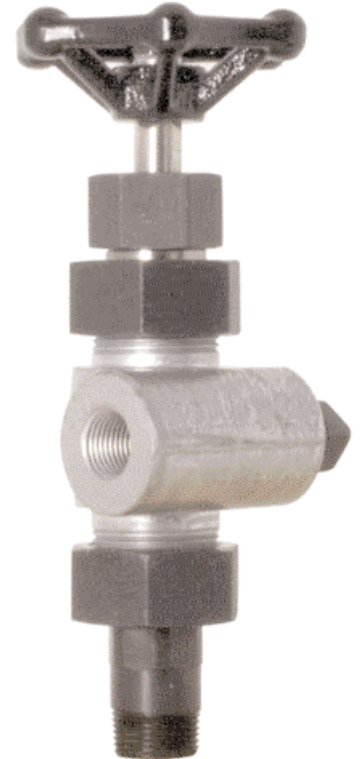
MODEL NO. 905

PRESSURE RATINGS

4000 psig at 100°F or 1700 psig at 600°F.

Exception: Model 945 (stuffing box) 1000 psig at 100°F.

STANDARD CONNECTIONS

Gauge: 1/2" NPT Female
Vessel: 3/4" NPT Male
Drain/Vent: 1/2" NPT Female

OPTIONAL CONNECTIONS

Gauge: 3/4" NPT Female
 1/2" or 3/4" NPT Male Union
 1/2" or 3/4" NPT Female Union

Vessel: 1/2" or 3/4" NPT Male Union
 1/2" or 3/4" NPT Female Union

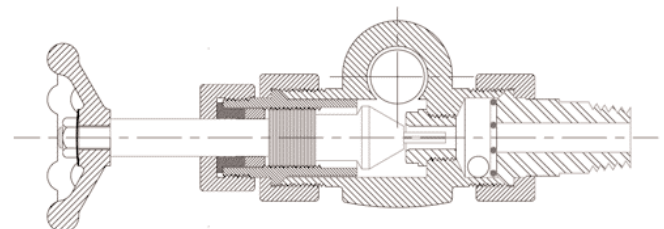
900 SERIES

sales@ARCHONind.com

ARMORED LIQUID LEVEL GAUGES

OPTIONAL CONNECTIONS TO VESSEL

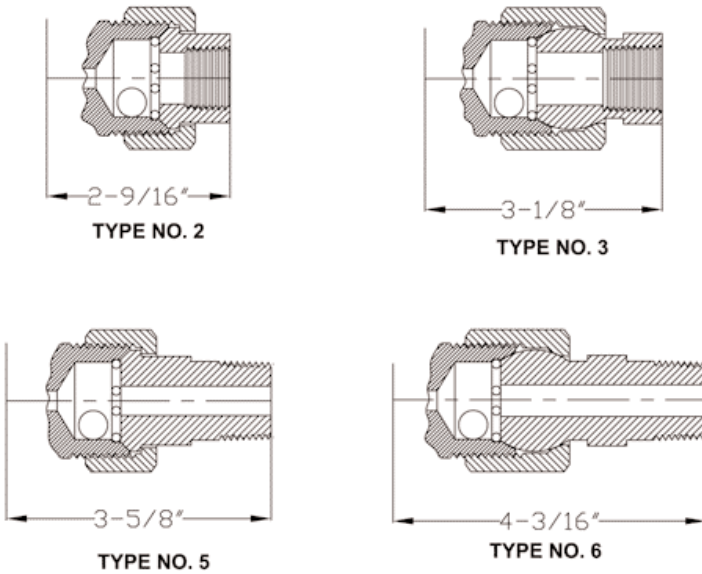

Gauge Cock models 951 thru 966 are NOT recommended for END CONNECTED GAUGES.

First Numeral: Indicates Type of Gauge Cock
 Second Numeral: Indicates Type of Connection to Gauge
 Third Numeral: Indicates Type of Connection to Vessel

Types of Connections

- 0-Threaded Connection
- 1-Female Union Connections
- 2-Female Spherical Union Connections
- 3-Stuffing box Connections
- 4-Male Union Connections
- 5-Male Spherical Union Connections

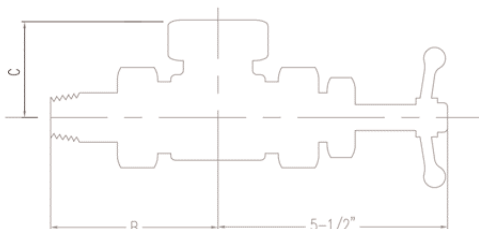

Dimension 'B': See Optional Connections to Vessel
 Dimension 'C': See Optional Connections to Gauge

Model Number	Connections to Gauge	Connections to Vessel
902	1/2" or 3/4" NPT Female	1/2" or 3/4" NPT Female Union
903	1/2" or 3/4" NPT Female	1/2" NPT Female Spherical Union
905	1/2" or 3/4" NPT Female	1/2" or 3/4" NPT Male Union
906	1/2" or 3/4" NPT Female	1/2" or 3/4" NPT Male Spherical Union
921	1/2" or 3/4" NPT Female Union	1/2" or 3/4" NPT Male Non-Union Solid Shank
922	1/2" or 3/4" NPT Female Union	1/2" or 3/4" NPT Female Union
923	1/2" or 3/4" NPT Female Union	1/2" NPT Female Spherical Union
925	1/2" or 3/4" NPT Female Union	1/2" or 3/4" NPT Male Union
926	1/2" or 3/4" NPT Female Union	1/2" or 3/4" NPT Male Spherical Union
931	1/2" NPT Female Spherical Union	1/2" or 3/4" NPT Male Non-Union Solid Shank
932	1/2" NPT Female Spherical Union	1/2" or 3/4" NPT Female Union
933	1/2" NPT Female Spherical Union	1/2" NPT Female Spherical Union
935	1/2" NPT Female Spherical Union	1/2" or 3/4" NPT Male Union
936	1/2" NPT Female Spherical Union	1/2" or 3/4" NPT Male Spherical Union
945	1/2", 5/8", 3/4" Stuffing Box	1/2" or 3/4" NPT Male Union
951	1/2" or 3/4" NPT Male Union	1/2" or 3/4" NPT Male Non-Union Solid Shank
952	1/2" or 3/4" NPT Male Union	1/2" or 3/4" NPT Female Union
953	1/2" or 3/4" NPT Male Union	1/2" NPT Female Spherical Union
955	1/2" or 3/4" NPT Male Union	1/2" or 3/4" NPT Male Union
956	1/2" or 3/4" NPT Male Union	1/2" or 3/4" NPT Male Spherical Union
961	1/2" or 3/4" NPT Male Spherical Union	1/2" or 3/4" NPT Male Non-Union Solid Shank
962	1/2" or 3/4" NPT Male Spherical Union	1/2" or 3/4" NPT Female Union
963	1/2" or 3/4" NPT Male Spherical Union	1/2" NPT Female Spherical Union
965	1/2" or 3/4" NPT Male Spherical Union	1/2" or 3/4" NPT Male Union
966	1/2" or 3/4" NPT Male Spherical Union	1/2" or 3/4" NPT Male Spherical Union

OPTIONAL CONNECTIONS TO GAUGE

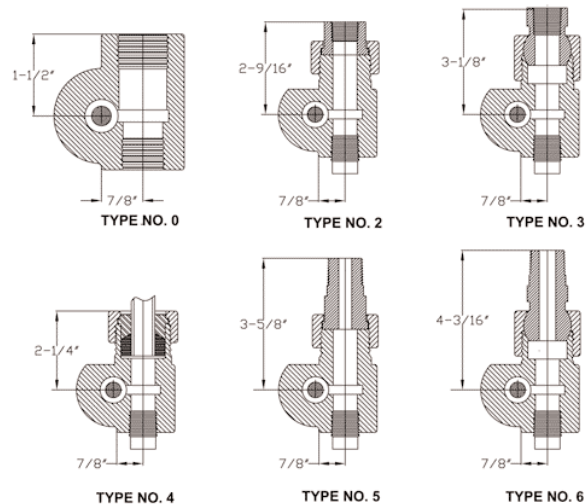

sales@ARCHONind.com

ARMORED LIQUID LEVEL GAUGES

SPARE PARTS

REFLEX

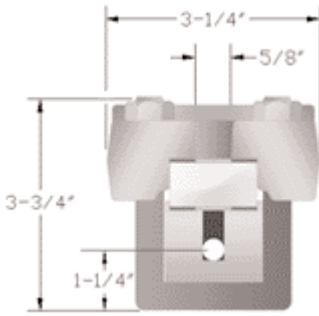

Cross Section

TRANSPARENT

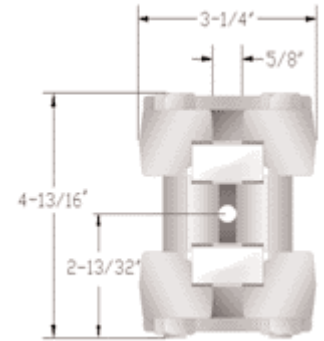

Cross Section

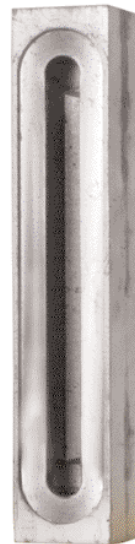
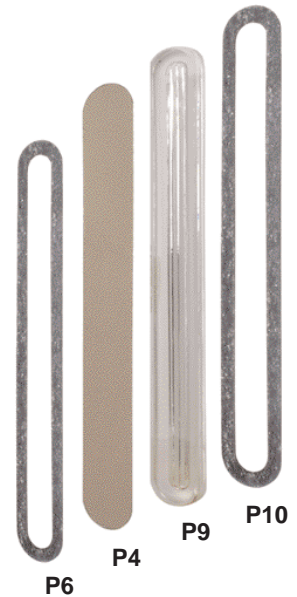

 Cover
P1

 Liquid Chamber
P2R (Reflex)
P2T (Transparent)

P6

P4

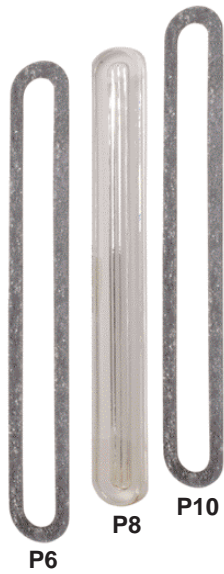
P9

P10



P6

P8

P10



P3

P3

P5



P7

P3

P12

sales@ARCHONind.com

ARMORED LIQUID LEVEL GAUGES

Side Connected Installations Close Hook-up

To obtain the maximum length of visibility within vessel centers, all ARCHON Reflex and Transparent gauges can be side-tapped. Mounting the gauge to the vessel can be achieved by choosing a style of flange, nipple or gauge cock most suitable to your application. Back connections are also available.

Standard centers for side connections are equal to the standard overall body length. Standard centers for back connections on transparent gauges are equal to the standard overall body length, and are 1-1/2" greater on the Transparent gauges.

Connections on all gauges are available in 1/2" or 3/4" NPT
(Please refer to the table on Page 9 for vessel center dimensions)

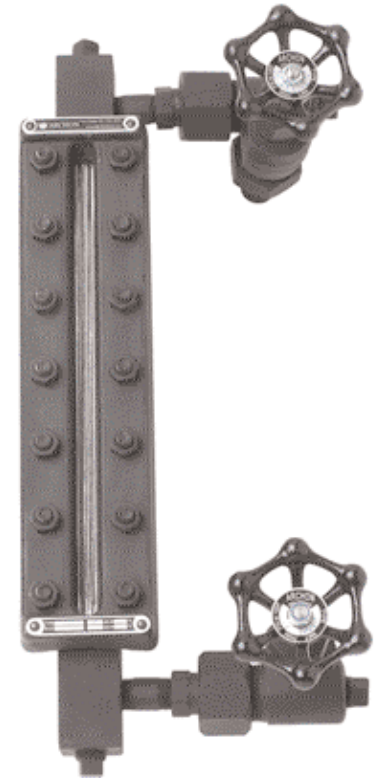

sales@ARCHONind.com

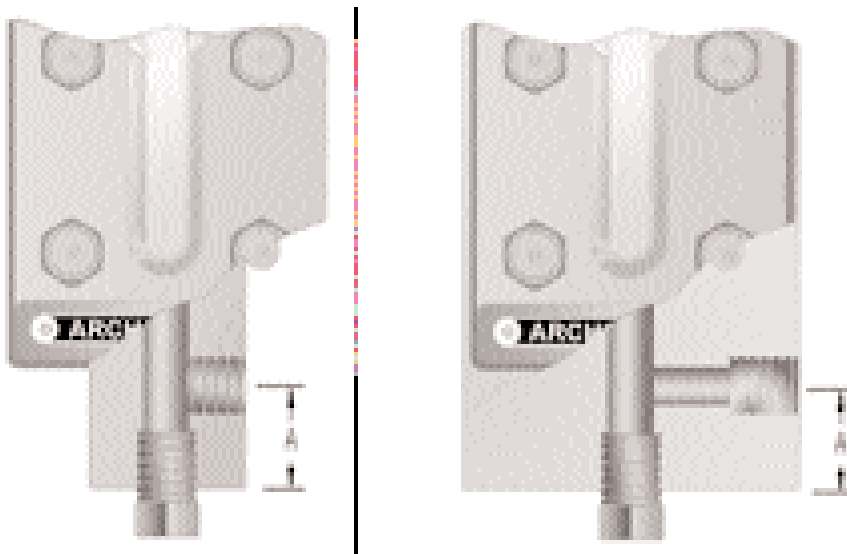

Size Connections

- 1/2" Side with 1/2" Top & Bottom
Dimension "A" = 1 1/8"
- 1/2" Side with 3/4" Top & Bottom
Dimension "A" = 1 1/2"
- 3/4" Side with 1/2" Top & Bottom
Dimension "A" = 1 1/2"
- 3/4" Side with 3/4" Top & Bottom
Dimension "A" = 1 3/4"

ARMORED LIQUID LEVEL GAUGES

END AND SIDE CONNECTED OPTIONAL ASSEMBLIES

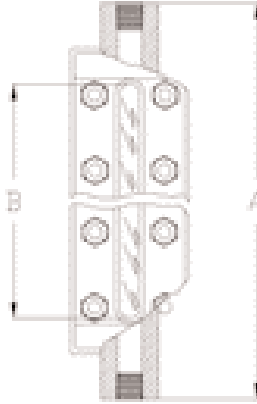

FIGURE NO. 1

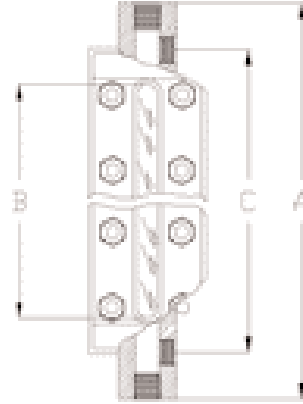

FIGURE NO. 2

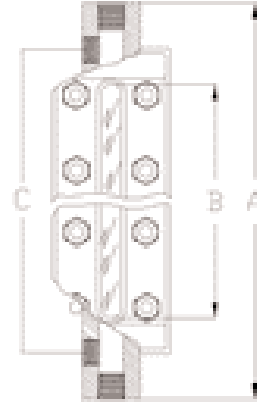

FIGURE NO. 2A

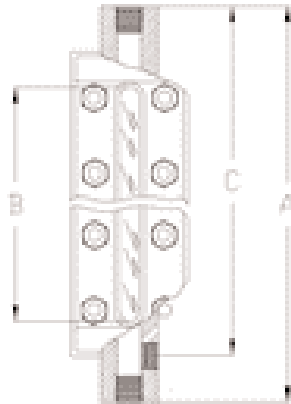

FIGURE NO. 3

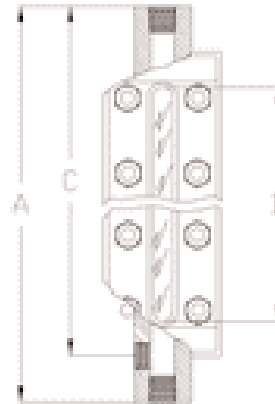

FIGURE NO. 3A

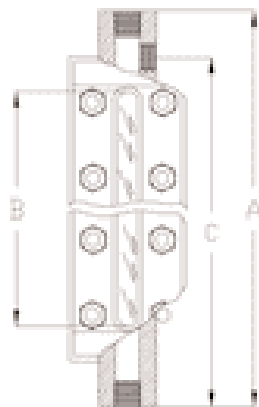

FIGURE NO. 4

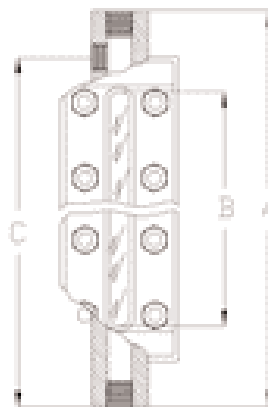

FIGURE NO. 4A

sales@ARCHONind.com

ARMORED LIQUID LEVEL GAUGES

FLANGED GAUGE ASSEMBLIES

Note: All Gauges and/or Gauge Cocks with Flanged Connections will be rated per ANSI B16.34 Flanged rating or Gauge rating, whichever is lower.

The Flanged Mounting arrangements described herein were drawn up to show possible configurations of our Reflex and Transparent Gauges. When specifying please indicate your preferred configuration by calling out the Style Number of the assembly, Size, Type, Pressure Rating of the flanges required and the "A", "C" and "D" dimensions. If you do not specify the Visibility "B" dimension desired we will provide maximum visibility according to the dimension given. Connections between the gauge and flanges can be furnished with or without welding.

FLANGE		A
Rating	Size	
150#	1/2"	1-7/8"
	3/4"	1-7/8"
	1"	2"
300#	1/2"	2"
	3/4"	2"
	1"	2-3/8"
600#	1/2"	2-1/4"
	3/4"	2-1/2"
	1"	2-5/8"
900# & 1500#	1/2"	3"
	3/4"	3-1/8"
	1"	3-1/2"



**Model RL
Flanged Assembly
Style No. 3FA**

sales@ARCHONind.com

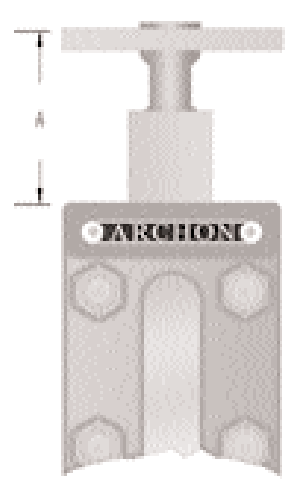
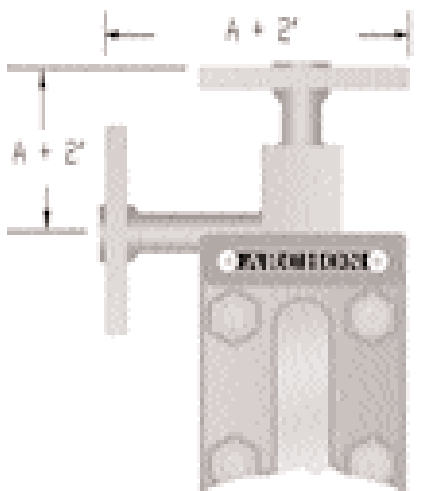

ARMORED LIQUID LEVEL GAUGES

OPTIONAL FLANGED GAUGE ASSEMBLIES

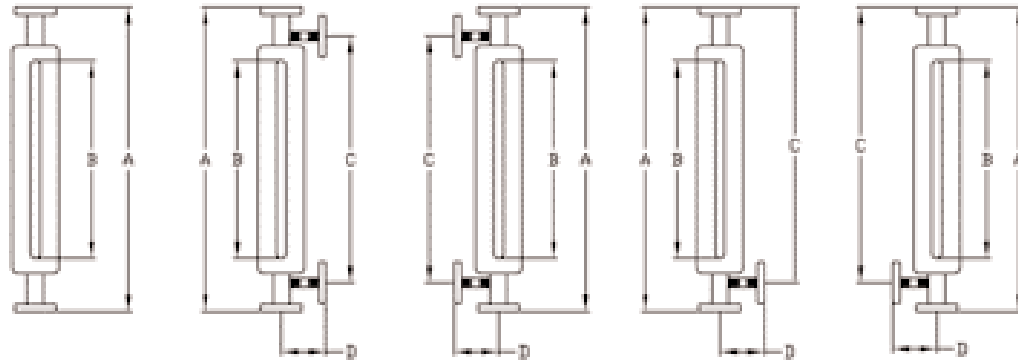

Style 1FA

Style 2FA

Style 3FA

Style 4FA

Style 5FA

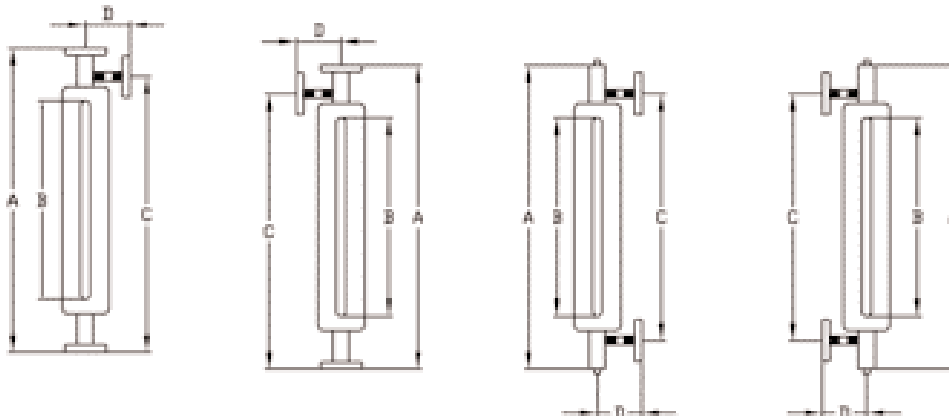

Style 6FA

Style 7FA

Style 8FA

Style 9FA

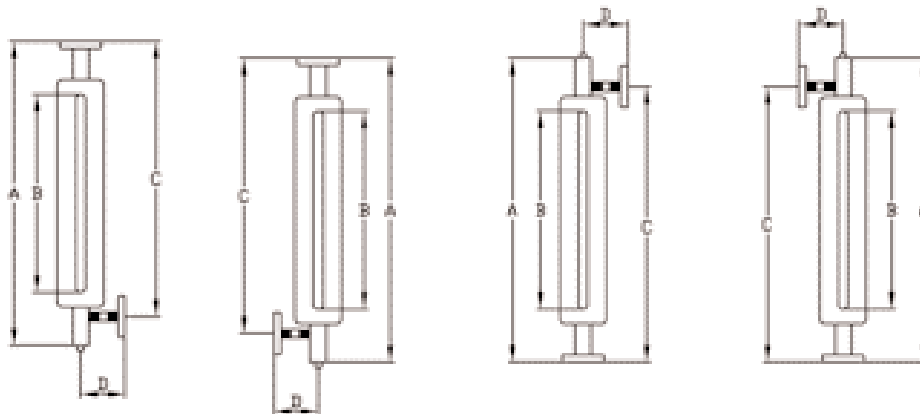

Style 10FA

Style 11FA

Style 12FA

Style 13FA

sales@ARCHONind.com

TUBULAR LIQUID LEVEL GAUGES

TUBULAR GLASS GAUGES

Forged Steel Gauge Cocks - Stainless Steel Trim
Integral Bonnet Design

Threaded Renewable Seats - Safety Ball Checks
Pyrex Tubular Glass - Guard Rods

Offset Type-Model No. 745

ARCHON's Tubular gauge assemblies are comprised of one pair of forged steel gauge cocks, four guard rods, guard rod holders and pyrex tubular glass. The gauge cocks have integral bonnets, stainless steel trim, a threaded renewable seat and stainless steel ball checks. The stainless steel stem is fitting with an extension tip to unseat the ball check when the valve is in the closed position. Gauge cocks have tapered union connections to the vessel for easier assembly and installation. The tubular glass connections are stuffing box type complete with a packing gland to prevent torsional stress on the glass when packing nuts are tightened.

Gauge cocks are typically furnished with handwheel operation, but can also be supplied with a lever.

Drain and vent connections are 1/2" or 3/4" female NPT and plugged.

CAUTION

Do not attempt to clean the inside of the tubular glass gauges with any abrasive object. Scratching the glass surface, particularly on the inside may weaken the glass and lead to damage.

Pressure Rating:

The maximum working pressure is directly dependent on the rating of the tubular glass.

OFFSET DESIGN

Shank Size	Glass Diam.	Gauge Cocks Model	Operation	Approx. Weight
1/2"	5/8"	No. 745	Hand Wheel	10 lbs
3/4"	3/4"	No. 745	Hand Wheel	10 lbs

DIMENSIONS

D	F
Glass Length	Visibility
E Less 2 1/4"	E less 4 1/2"

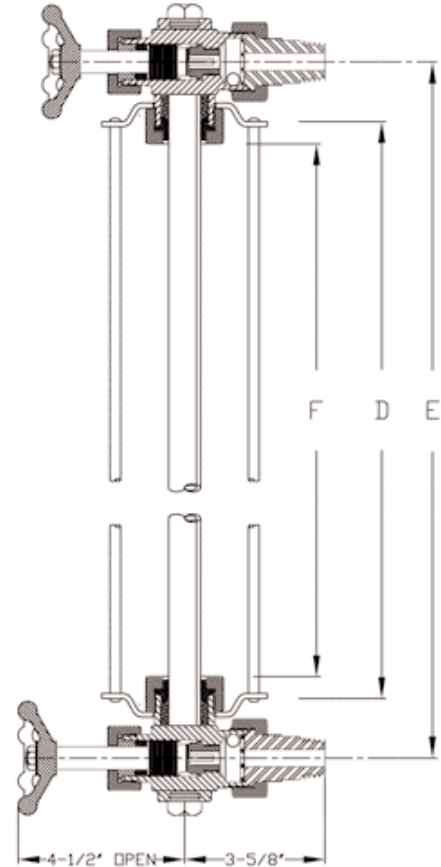

MODEL NO.745

sales@ARCHONind.com

TUBULAR LIQUID LEVEL GAUGES

TUBULAR GLASS GAUGES

Forged Steel Gauge Cocks - Stainless Steel Trim
Union Bonnet Design

Threaded Renewable Seats - Safety Ball Checks
Pyrex Tubular Glass - Guard Rods

Offset Type-Model No. 945

ARCHON's Tubular gauge assemblies are comprised of one pair of forged steel gauge cocks, four guard rods, guard rod holders and pyrex tubular glass. The gauge cocks have union bonnets, stainless steel trim, a threaded renewable seat and stainless steel ball checks. The stainless steel stem is fitting with an extension tip to unseat the ball check when the valve is in the closed position. Gauge cocks have tapered union connections to the vessel for easier assembly and installation. The tubular glass connections are stuffing box type complete with a packing gland to prevent torsional stress on the glass when packing nuts are tightened.

Gauge cocks are typically furnished with handwheel operation, but can also be supplied with a lever.

Drain and vent connections are 1/2" or 3/4" female NPT and plugged.

CAUTION

Do not attempt to clean the inside of the tubular glass gauges with any abrasive object. Scratching the glass surface, particularly on the inside may weaken the glass and lead to damage.

Pressure Rating:

The maximum working pressure is directly dependent on the rating of the tubular glass.

OFFSET DESIGN

Shank Size	Glass Diam.	Gauge Cocks Model	Operation	Approx. Weight
1/2"	5/8"	No. 945	Hand Wheel	11 lbs
3/4"	3/4"	No. 945	Hand Wheel	11 lbs

DIMENSIONS

D	F
Glass Length E Less 2 1/4"	Visibility E less 4 1/2"

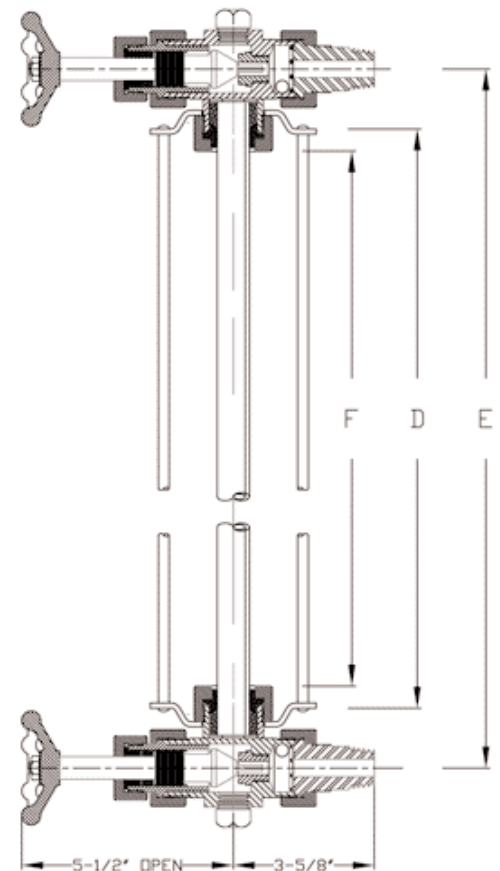

MODEL NO.945

TUBULAR LIQUID LEVEL GAUGES

TUBULAR GAUGES

ARCHON SAFETY GAUGE GLASS PROTECTOR SGP - 18

The ARCHON model SGP-18 consists of a piece of round clear plastic tube, with a metal retainer on each end and four rods. The tube is slotted at the rear for the entire length so that it can be slipped over the tubular gauge glass without any interference. It is quick and simple to install or remove.



sales@ARCHONind.com

Maximum Recommended Working Pressure-PSIG

Type Glass	High Pressure Pyrex Tubular Glass		Red Line Pyrex Tubular Glass		Heavy Wall Pyrex Tubular Glass	
	Glass Length	Temperatures Up to 150°F No Corrosion	Temperatures Up to 150°F No Corrosion	Steam Boiler Service Up to 425°F	Temperatures Up to 150°F No Corrosion	Steam Boiler Service Up to 425°F
Up to 12"	400	300	330	275	600	340
13" to 18"	355	275	300	260	600	320
19" to 24"	315	250	260	250	580	300
25" to 30"	275	***	230	***	550	***
31" to 36"	240	***	200	***	500	***
37" to 48"	190	***	160	***	340	***
49" to 60"	145	***	125	***	Maximum Length 48" Long	
61" to 72"	100	***	90	***		

*** NOT RECOMMENDED FOR SERVICE AT THIS TEMPERATURE

TUBULAR GLASS GAUGES & EXPLOSION PROOF ILLUMINATOR MODEL XPI-20

Tubular Glass Gauges

All ARCHON Tubular Gauges share the following quality features:

Standard Features:

- Forged gauge cocks
- Safety ball checks
- Tubular borosilicate glass
- Four protective guard rods
- 300psi Maximum pressure @ 150°F (Red Line Glass).
- 400psi Maximum pressure @ 150°F (High Pressure Glass).
- 600psi Maximum pressure @ 150°F (Heavy Wall Glass).
- 200psi Maximum pressure @ 150°F (Models 504, 505 and 507)

Tubular Gauge With Model 745 Gauge Cocks

This level gauge consists of a pair of our offset forged gauge cocks with integral bonnet design and $\frac{5}{8}$ " or $\frac{3}{4}$ " diameter sight glass. The Tubular Gauge with Model 745 Gauge Cocks is available in carbon steel, carbon steel with SS wetted parts or all 316SS parts.

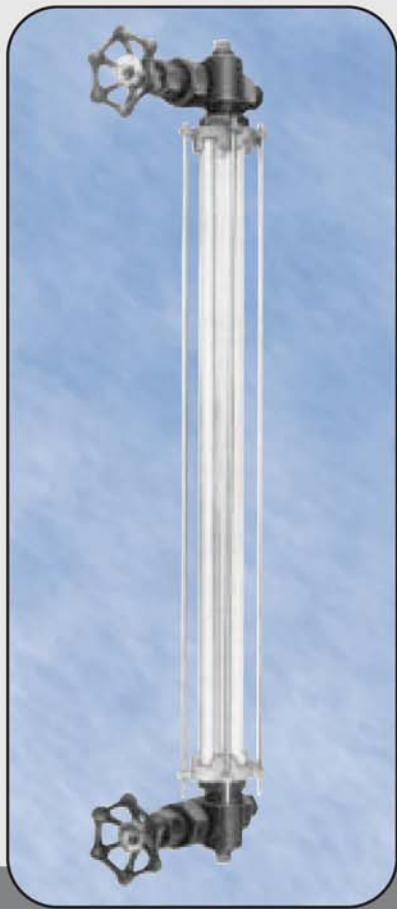

*Tubular Gauge with
Model 945 Gauge Cocks
with SGP-18 Glass Protector*

Tubular Gauge With Model 945 Gauge Cocks

This level gauge consists of a pair of our offset forged gauge cocks with union bonnet design and $\frac{5}{8}$ " or $\frac{3}{4}$ " diameter sight glass. The Tubular Gauge with Model 945 Gauge Cocks is available in carbon steel, carbon steel with SS wetted parts, Monel or Alloy-20 wetted parts or all 316SS parts.

NEW!

Brass Tubular Gauge Models 504, 505 and 507

These level gauges consist of a pair of forged brass gauge cocks and $\frac{5}{8}$ " or $\frac{3}{4}$ " diameter sight glass.

SGP-18 Safety Glass Gauge Protector For Tubular Gauge

The ARCHON tubular gauge protector consists of a round clear plastic tube and a pair of metal retainers and four guard rods.

Explosion Proof Thru-Vision Gauge Illuminator Model XPI-20

The ARCHON Explosion Proof Illuminator Model XPI-20 distributes a uniform and brighter light for the entire length of the sight glass. The illuminator uses a plastic wedge mounted behind the gauge with an air space between the wedge and the sight glass. The model XPI-20 is UL approved for hazardous locations, Class I, Groups B, C & D.

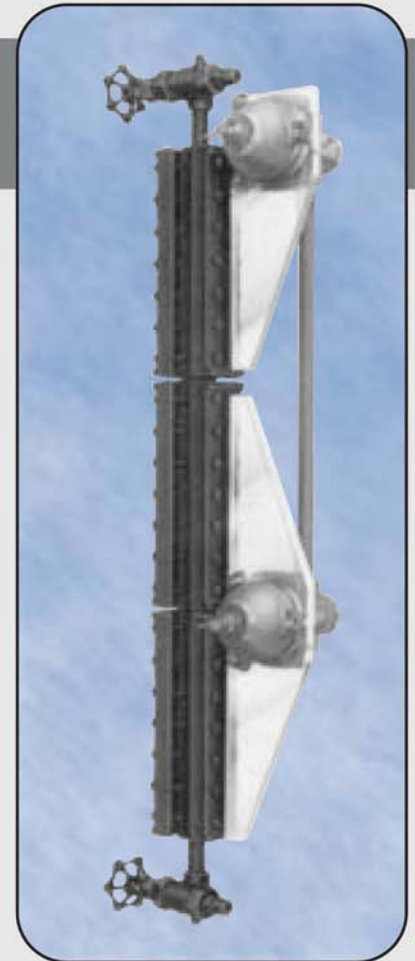

*Thru-Vision Gauge with
Model XPI-20 Illuminator*





ARCHON

GAUGE COCKS

Offset Style Gauge Cocks

ARCHON's line of offset type forged gauge cocks are designed to allow easy cleaning of the inside of the gauge. The drain and vent connections are on center with the liquid chamber and offset $\frac{7}{8}$ " from the vessel connections. With this style body it is possible to clean the inside of an end connected gauge without removing it from service. All of ARCHON's offset style gauge cocks share the following features:

Standard Features:

- Forged Steel bodies, Stainless Steel trim
- Safety ball checks
- Screwed renewable seat
- $\frac{1}{2}$ " or $\frac{3}{4}$ " female NPT gauge connection
- $\frac{3}{4}$ " male union NPT vessel connection
- $\frac{1}{2}$ " female NPT vent & drain connections (Models 701-706 and 901-906)
- $\frac{3}{4}$ " female NPT vent & $\frac{1}{2}$ " female NPT drain connections (Models 721-766 and 921-966)
- Integral bonnet - Series 700
- Union bonnet - Series 900
- 4000psi Maximum pressure @ 100°F
- 1500psi Maximum pressure @ 750°F



*Gauge Cock Model
725*

Optional Features:

- $\frac{1}{2}$ " or $\frac{3}{4}$ " female NPT union connections
- $\frac{1}{2}$ " or $\frac{3}{4}$ " female NPT spherical union connections
- $\frac{1}{2}$ " or $\frac{3}{4}$ " male NPT union connections
- $\frac{1}{2}$ " or $\frac{3}{4}$ " male NPT spherical union connections
- $\frac{1}{2}$ " or $\frac{3}{4}$ " male NPT solid shank vessel connections
- Monel or Alloy 20 body with 316SST wetted parts (Series 900)

OS&Y Style Gauge Cocks

The ARCHON BB-100 Series bolted bonnet gauge cocks have a forged bonnet and separate stem packing gland. The design of the BB-100 places the threaded portion of the valve stem outside of the body to prevent contact with the process fluid. The stem itself is a backseating design that allows the valve to be repacked while in service and under pressure. The BB-100 series includes a renewable seat and safety ball check.

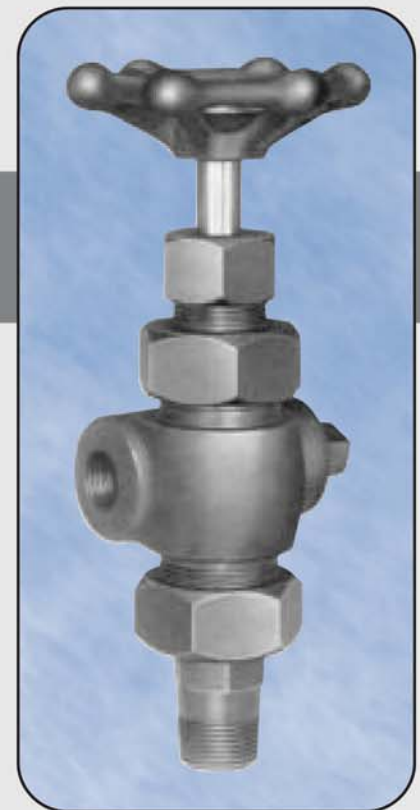

*Gauge Cock Model
905*

DISTRIBUTED BY:

ARCHON Industries, Inc.
357 Spook Rock Road
Suffern, NY 10901
Phone: 845-368-3600
Fax: 845-368-3040
Website: www.ARCHONind.com



ARCHON Industries • 357 Spook Rock Road • Suffern, New York 10901